



FAI Sporting Code

*Fédération
Aéronautique
Internationale*

Section 4 – Aeromodelling

Volume F3 Radio Control Aerobatics

2010 Edition

Effective 1st January 2010

F3A – R/C AEROBATIC POWER MODEL AIRCRAFT
F3M - LARGE R/C AEROBATIC POWER MODEL AIRCRAFT
F3P - INDOOR R/C AEROBATIC POWER MODEL AIRCRAFT
ANNEX 5A - F3A DESCRIPTION OF MANOEUVRES
ANNEX 5B F3A JUDGES' GUIDE
ANNEX 5G - F3A UNKNOWN MANOEUVRE SCHEDULES
ANNEX 5 L - F3M DESCRIPTION OF MANOEUVRES
ANNEX 5M - F3P DESCRIPTION OF MANOEUVRES
ANNEX 5N - F3A WORLD CUP RULES



*Avenue Mon-Repos 24
CH-1005 Lausanne
(Switzerland)
Tél.: +41(0) 21/345.10.70
Fax: +41(0) 21/345.10.77
E-mail: sec@fai.org
Web: www.fai.org*

FEDERATION AERONAUTIQUE INTERNATIONALE

Avenue Mon Repos 24, 1005 LAUSANNE, Switzerland

Copyright 2010

All rights reserved. Copyright in this document is owned by the Fédération Aéronautique Internationale (FAI). Any person acting on behalf of the FAI or one of its Members is hereby authorised to copy, print, and distribute this document, subject to the following conditions:

- 1. The document may be used for information only and may not be exploited for commercial purposes.**
- 2. Any copy of this document or portion thereof must include this copyright notice.**

Note that any product, process or technology described in the document may be the subject of other Intellectual Property rights reserved by the Fédération Aéronautique Internationale or other entities and is not licensed hereunder.

RIGHTS TO FAI INTERNATIONAL SPORTING EVENTS

All international sporting events organised wholly or partly under the rules of the Fédération Aéronautique Internationale (FAI) Sporting Code¹, are termed *FAI International Sporting Events*². Under the FAI Statutes³, FAI owns and controls all rights relating to FAI International Sporting Events. FAI Members⁴ shall, within their national territories⁵, enforce FAI ownership of FAI International Sporting Events and require them to be registered in the FAI Sporting Calendar⁶.

Permission and authority to exploit any rights to any commercial activity at such events, including but not limited to advertising at or for such events, use of the event name or logo for merchandising purposes and use of any sound and/or image, whether recorded electronically or otherwise or transmitted in real time, must be sought by way of prior agreement with FAI. This includes specifically all rights to the use of any material, electronic or other, that forms part of any method or system for judging, scoring, performance evaluation or information utilised in any FAI International Sporting Event⁷.

Each FAI Air Sport Commission⁸ is authorised to negotiate prior agreements on behalf of FAI with FAI Members or other entities as appropriate, of the transfer of all or parts of the rights to any FAI International Sporting Event (except World Air Games events⁹) which is organised wholly or partly under the Sporting Code section¹⁰ for which that Commission is responsible¹¹. Any such transfer of rights shall be by "Organiser Agreement"¹² as specified in the current FAI Bylaws Chapter 1, para 1.2 "Rules for Transfer of Rights to FAI International Sporting Events".

Any person or legal entity which accepts the responsibility for organising an FAI Sporting Event, whether or not by written agreement, in doing so also accepts the proprietary rights of FAI as stated above. Where no formal transfer of rights has been established, FAI retains all rights to the event. Regardless of any agreement or transfer of rights, FAI shall have, free of charge for its own archival and/or promotional use, full access to any sound and/or visual images of any FAI Sporting Event, and always reserves itself the right to have any and all parts of any event recorded, filmed and/or photographed for such use, without charge.

1 FAI Statutes, Chapter 1, para. 1.6

2 FAI Sporting Code, General Section, Chapter 3, para 3.1.3

3 FAI Statutes, Chapter 1, para 1.8.1

4 FAI Statutes, Chapter 2, para 2.1.1; 2.4.2 ; 2.5.2 ; 2.7.2

5 FAI Bylaws, Chapter 1, para 1.2.1

6 FAI Statutes, Chapter 2, para 2.4.2.2.5

7 FAI Bylaws, Chapter 1, para 1.2.3

8 FAI Statutes, Chapter 5, para 5.1.1; 5.5 ; 5.6

9 FAI Sporting Code, General Section, Chapter 3, para 3.1.7

10 FAI Sporting Code, General Section, Chapter 1, paras 1.2. and 1.4

11 FAI Statutes, Chapter 5, para 5.6.3

12 FAI Bylaws, Chapter 1, para 1.2.2

PAGE DELIBERATELY LEFT BLANK

VOLUME F3 AEROBATICS

SECTION 4C - MODEL AIRCRAFT - F3A - RADIO CONTROL AEROBATICS

Part Five – Technical Regulations for Radio Controlled Contests

- 5.1. Class F3A - Aerobatic Power Model Aircraft
- 5.10 Class F3M - Large Aerobatic Power Model Aircraft
- 5.9 Class F3P - Indoor Aerobatic Power Model Aircraft

- Annex 5A F3A - Description of Manoeuvres
- Annex 5B - F3A - Judges' Guide
- Annex 5G - F3A - Unknown Manoeuvre Schedules
- Annex 5 L - F3M - Description of Manoeuvres
- Annex 5M - F3P - Description of Manoeuvres
- Annex 5N - F3A - World Cup

THIS 2010 EDITION INCLUDES THE FOLLOWING AMENDMENTS MADE TO THE 2009 CODE

These amendments are marked by a double line in the right margin of this edition

Paragraph	Plenary meeting approving change	Brief description of change	Change incorporated by
Front page, page 5	n/a	Consequential changes regarding 5.9 & 5.10 as official classes	Jo Halman Technical Secretary
Page 9		Updated the rule freeze paragraph	
Page 11		Corrected title	
5.1.3	2009	Specified requirements for disabled competitors	Michael Ramel S-C Chairman
5.1.5		Simplified definition of an attempt	
5.1.11		Precision of time keeping	
5.1.11		Correction of reference	
5.1.12		Precision of execution of manoeuvres	
5.1.13		Correction of manoeuvre description	
Annex 5A	n/a	Deleted obsolete manoeuvre schedules and diagrams P.09 & F.09	Michael Ramel S-C Chairman
Annex 5A: P-11.01		Rationale correction: deleted "up"	
P-11.07,		Rationale correction: "complete" to "perform" add "with"	
P-11.08		Rationale correction: delete "in either direction"	
P-11.13		Rationale correction: delete "to complete"; insert "through" and amend text in Judging Notes 2nd bullet point	
P-11.16		Rationale correction: delete "to complete"; insert "through"	
P-11.17		Corrected text for clarification; changed "Spin" to "Turn" in Judging Notes 3rd bullet point	
F-11.02		Rationale correction: delete "to complete"; insert "through"	
F-11.05		Corrected to correspond to the Judges Guide	
F-11.09		Rationale correction: delete "to complete"; insert "through"	
F-11.16		Added Judging notes as corresponding manoeuvre in F3A	
Annex 5 G			
5.10	2008	F3M from Provisional (Annex 5L) to Official class 5.10. Rules renumbered and relocated; (late correction)	
5.10.10	n/a	Corrected normalisation formula	Jo Halman Technical Secretary
5.10.13		Corrected for English	
5.10.14		Deleted unnecessary date & corrected cross-reference	
5.10.15		Amended title to follow rationale	
Annex 5L		Amended title for clarity & protocol; added note at end	
5.9		F3P from Provisional (Annex 5M) to Official class 5.9	
5.9.9		Deleted erroneous "semi-finals"	
5.9.10 c)		Inserted omitted text	
5.9.10 e)		Deleted erroneous "unknown"	
5.9.10 f)		Corrected cross reference	
5.9.11		Corrected cross reference	

cont/...

Paragraph	Plenary meeting approving change	Brief description of change	Change incorporated by
5.9.13	n/a	AP-07 corrected to "half roll down"	Michael Ramel S-C Chairman
5.9.13		AP-08 corrected to "centre manoeuvre"	
5.9.14		Amended title to follow protocol	
5.9.8, 5.9.12 c), e), g), j), l, 5.9.13, Annex 5M		All occurrences and references to "AeroMusicals" are now "Aerobatics Freestyle to Music" and "AM" are now "AFM"	
Annex 5M		Amended titles to follow protocol	Technical Secretary
Annex 5M, AP10		AP-10 amended Judging Notes to specify "distance from"; added notes regarding location of manoeuvre descriptions.	Michael Ramel S-C Chairman
Annex 5N.3b	2009	Redefinition of World Cup scores	

Four-Year Rolling Amendments for Reference			
Paragraph	Plenary meeting approving change	Brief description of change	Change incorporated by
5.1.11	n/a	Corrected reference.	Technical Secretary
5.1.13		P-11.14 deleted erroneous "inverted text"	Bob Skinner S-C Chairman
Annex 5L.1.10		Deleted erroneous "S" from the formula	
5L.1.14	2008	Added 2009-2010 manoeuvre schedules list & K factors	Bob Skinner S-C Chairman
Annex 5L. Appendix 1		Added 2009-2010 description of the manoeuvres and Aresti diagrams	
Annex 5M.1.2		Increased maximum weight to 300g	
Annex 5M.1.9		Additional rules regarding the new F3P-AP & F3P-AF schedules	
Annex 5M.1.10		Additional judging rules; added sub-paragraph number for clarity	
Annex 5M.1.12	n/a	Consequential change reference F3P-AP & F3P-AF	Technical Secretary
Annex 5M.1.3	2008	Added explanation of F3P-AP & F3P-AF and the lists of manoeuvres and K factors; added references to the four new appendices required by the new schedules	Bob Skinner S-C Chairman
Annex 5M.1.14	n/a	Delete "Description" and added reference to F3P-AF	Technical Secretary
Annex 5M. Appendices 1,2	2008	Added two new appendices for F3P-AP manoeuvre descriptions and diagrams	Bob Skinner S-C Chairman
Annex 5M. Appendices 3,4		Added two new appendices for F3P-AF manoeuvre descriptions and diagrams	
Annexes 5A, 5B, 5G & 5N	2007	Plenary approved the re-numbering of these annexes to 5.2, 5.3, 5.4 & 5.5 respectively but those numbers belong to other volumes and so the existing title and paragraph numbering has been retained.	Bob Skinner S-C Chairman & Jo Halman Technical Secretary
Part 5 - Page 5		Addition of listing for Annex 5N, World Cup rules.	
5.1.2 – 5.1.13 excluding 5.1.7		Wholly re-written paragraphs including English corrections and standardised word usage.	
Annex 5A.1.13		First paragraph: addition of "recognisable distance" and paragraph restructure.	
Annex 5A.1.13		Second paragraph: addition of "or a combination".	
Annex 5A.1.13		Fourth paragraph: addition of "sub-committee approved".	

Four-Year Rolling Amendments for Reference				
Paragraph	Plenary meeting approving change	Brief description of change	Change incorporated by	
Annex 5A.1.13	Consequential change	New paragraph at five.	Bob Skinner S-C Chairman & Jo Halman Technical Secretary	
Annex 5A	2007	New schedules of manoeuvres for P-09, F-09, P-11, F-11; manoeuvre descriptions; Aresti diagrams.		
Annex 5B.1		Deleted and added text.		
Annex 5B.2		Last paragraph has deleted and added text.		
Annex 5B.3		First paragraph has deleted and added text. New third paragraph. Corrected English.		
Annex 5B.4		Last paragraph has deleted and added text.		
Annex 5B.7		Deleted and added text.		
Annex 5B.7.1		Paragraphs one, two & four have added text.		
Annex 5B.7.2		Paragraph two has added text.		
Annex 5B.7.3		Paragraphs one, a) & c) have added text. Paragraph d) has deleted and added text.		
Annex 5B.7.4		Paragraph three has added text and the last paragraph has deleted and added text.		
Annex 5B.7.5		Paragraphs one and three have added text and paragraph two has deleted and added text.		
Annex 5B.7.6		Paragraph one has deleted and added text. Paragraphs two, three and four have added text.		
Annex 5B.7.7		Paragraph two had added text. New paragraph at four.		
Annex 5B.7.8		Whole new item of four paragraphs		
Annex 5B.7.9		Whole new item of two paragraphs		
Annex 5B.9		Paragraphs one and four have deleted and added text. New paragraph four and existing paragraph four is now paragraph five.		
Annex 5B.10		Paragraphs 4, 7 & 8 dealing with landing are all deleted. Paragraph nine has some deleted text. Paragraph 18 has some deleted and added text. Paragraph 19 has some added text.		
Annex 5G.2		First paragraph and sub-paragraph 7 have deleted and added text. Sub-paragraphs: 8 change "19" to "17" and delete take-off & landing text and 8a) deleted and added text. New sub-paragraph 9. Corrected English		
Annex 5G.3		Added text.		
Annex 5G.4		Corrected English		
Annex 5G.6	Deleted and added text and corrected English.			
Annex 5L.13 d)	Formula corrected.			
Annex 5N	Wholly new annex for World Cup.			
5L.1	n/a	Title amended to bring in line with current naming policy		Jo Halman Technical Secretary December 2006
5L.14.c-		Two information lines added at end of K factors		
5L.1.15 & 16.		Added para number to Marking Criteria; subsequently re-numbered 5L.1.16 & moved Diversity from Safety to Performing of Manoeuvres.		
Manoeuvre Descriptions		Added Annex title & amended the title to bring in line with current naming policy.		
5L Appendix 1		Added appendix title		
5L Appendix 2		Added appendix title		
5M.1 & 1.2		Title amended to bring in line with current naming policy		
5M.1.13		F3P-A schedule relocated to follow current conventions		
5M.1.14 & 15		Added class designation to the title for clarity.		
5M Appendix 1		Added appendix title		

Four-Year Rolling Amendments for Reference			
Paragraph	Plenary meeting approving change	Brief description of change	Change incorporated by
75L.1.3.	2006	Amended noise criteria and procedure	Bob Skinner S-C Chairman
5L.1.3. d-		Model dimension & formula including a diagram	
5L.1.9.		Change to 70 degrees	
5L.14.b-		Patterns must be used according to the full size Aresti catalogue	
5L.14.c-		New F3M known schedule K-factors	
5L - Appendix 1		F3M New description of manoeuvres for known schedule	
5L - Appendix 2		F3M New Aresti diagrams for known schedule	
5M.1.8		Judging by whole numbers	
AM2 Freestyle		Amended throughout: the four elements	
AM3 Landing		Any kind of landing provided it is in a safe manner.	

RULE FREEZE FOR THIS VOLUME

With reference to paragraph A.12 of Volume ABR:

In all classes, the two-year rule for no changes to model aircraft/space model specifications, manoeuvre schedules and competition rules will be strictly enforced, but in step with the World Championship cycle of each category. This means that in Volume F3 Aerobatics:

- a) changes can next be agreed at the Plenary meeting 2011 for application from January 2012;
- b) provisional classes are not subject to this restriction.

The only exceptions allowed to the two-year rule freeze are genuine and urgent safety matters, indispensable rule clarifications and noise rulings.

PAGE DELIBERATELY LEFT BLANK

VOLUME F3 AEROBATICS

PART FIVE - TECHNICAL REGULATIONS FOR RADIO CONTROLLED CONTESTS

5.1. CLASS F3A - AEROBATIC POWER MODEL AIRCRAFT

5.1.1. Definition of a Radio Controlled Aerobatic Power Model Aircraft

A model aircraft, but not a helicopter, which is aerodynamically manoeuvred by control surface(s) in attitude, direction, and altitude by a pilot on the ground using radio control.

5.1.2. General Characteristics of Radio Controlled Aerobatic Power Models:

Maximum overall span2000mm

Maximum overall length2000mm

Maximum total weight, with batteries5000g

A tolerance of 1% will be allowed for possible inconsistencies in measurement instruments for size, weight, and voltage unless otherwise stated.

Propulsion device limitations: Any suitable propulsion device may be utilised. Propulsion devices that are not permitted are those requiring solid expendable propellants, gaseous fuels (at room temperature and atmospheric pressure), or liquefied gaseous fuels. Electric powered model aircraft are limited to a maximum of 42.56 volts for the propulsion circuit, measured off load, and prior to flight while the competitor is in the ready box.

Paragraph B.3.1.a) of Section 4B (Builder of Model aircraft) is not applicable to class F3A.

The maximum sound/noise level of the model aircraft and its propulsion device, shall be 94 dB(A) measured at 3m from the centre line of the model aircraft with the model aircraft placed on the ground over concrete, macadam, grass, or bare earth at the flight line.

The tolerance of the sound/noise level measurement is the specified tolerance of the manufacturer of the measuring instrument.

With the propulsion device running at full power, the measurement will be taken 90 degrees on the right-hand side, with the nose of the model aircraft pointing into the wind. The Class 1 SLM (Sound Level Meter) microphone shall be placed on a stand 30cm above the ground in line with the propulsion device Other than the helper restraining the model aircraft, and the sound steward, no persons or sound/noise reflecting or sound absorbing objects shall be nearer than 3m to the model aircraft or the microphone. The sound/noise measurement shall be made immediately prior to each flight. The sound test area must be located in a position that does not create a safety hazard to officials and other competitors.

The flight time will be interrupted while the sound/noise test at the flying site is being made. The competitor shall not be delayed more than 30 seconds for this sound test.

In the event of a model aircraft failing the sound/noise test, no indication of the result or the reading shall be given to the competitor, or his team, or the judges, and both the transmitter and the model aircraft shall be impounded by the flight line official immediately following the flight. No modification or adjustment to the model aircraft shall be permitted (other than refuelling or battery recharging). The competitor and his equipment shall remain under supervision of the flight line director. The model aircraft shall be re-tested within 30 minutes by a second noise steward using a second Sound Level Meter, and in the event that the model aircraft fails the re-test, the score for the preceding flight shall be zero. The score for the flight may be tabulated but not made public until the result of the re-test is communicated to the tabulators.

Radio equipment shall be of the open loop type (ie no electronic feedback from the model aircraft to the ground). Auto-pilot control utilising inertia, gravity or any type of terrestrial reference is prohibited. Automatic control sequencing (pre-programming) or automatic control timing devices are prohibited.

Example: Permitted:

1. Control rate devices that are manually switched by the pilot.
2. Any type of button or lever, switch, or dial control that is initiated or activated and terminated by the competitor.
3. Manually operated switches or programmable options to couple and mix control functions.

Not permitted:

1. Snap roll buttons with automatic timing mode.
2. Pre-programming devices to automatically perform a series of commands.
3. Auto-pilots or gyros for automatic wing levelling or other stabilisation of the model aircraft.
4. Propeller pitch change with automatic timing mode.
5. Any type of voice recognition system.
6. Conditions, switches, throttle curves, or any other mechanical or electronic device that will prevent or limit maximum power or rpm of the propulsion device during the sound/noise test.
7. Any type of learning function involving manoeuvre to manoeuvre or flight to flight analysis.

5.1.3. **Definition and Number of Helpers**

A helper may be a Team Manager, another competitor, or an officially registered supporter. Each competitor is permitted one helper (usually the caller) during the flight. Two helpers may be present and assist during the starting of the motor(s). One person, either a helper, or the team manager, or the caller, may place the model aircraft for take-off and retrieve the model aircraft following the landing. In exceptional circumstances, another helper may join the competitor and caller/helper during the flight, but only to hold a sun-shield as protection from direct sunlight. These protection devices must not interfere with the judges' vision of the manoeuvres. Physically disabled competitors requiring an additional helper and/or caller or other assistance, must request permission with full details, with their entry, from the organiser of a championship. This additional assistance must be provided by the competitor, must not give him an unfair advantage over other competitors, and must not unduly delay or interfere with the running of the competition. Except for communication between the caller and the competitor, no other performance-enhancing communication with helpers is permitted during the flight.

5.1.4. **Number of Flights**

Competitors have the right to the same number of preliminary, semi-final, or finals flights. Only completed rounds will be counted. Only when all competitors in the preliminary, semi-final, and final rounds, have had the opportunity to complete the same number of rounds, can the results of the rain-interrupted (or other delay) competition be determined.

5.1.5. **Definition of an Attempt**

There is an attempt when the competitor is given permission to start.

If the propulsion device stops after the take-off has begun, the attempt will be deemed complete.

5.1.6. **Number of Attempts**

Each competitor is entitled to one attempt for each official flight.

Note: An attempt can be repeated at the contest director's discretion only when any unforeseen reason beyond the control of the competitor, causes the model aircraft to fail to start (eg there is radio interference). Similarly, in a flight that is interrupted by any circumstance beyond the control of the competitor, the competitor is entitled to a reflight, with the entire schedule being flown and judged, but only the affected manoeuvre and the unscored manoeuvres that follow will be tabulated. This reflight should take place within 30 minutes of the first flight, in front of the same set of judges, or be the first flight after the judges' break, or, if it involves a protest, as soon as the FAI Jury has deliberated and communicated the outcome of the protest to the contest director. The result of the reflight will be final.

5.1.7. **Definition of an Official Flight**

There is an official flight when an attempt is made whatever the result.

5.1.8. **Marking**

Each manoeuvre may be awarded marks, in whole numbers, between 10 and 0 by each of the judges during the flight. During tabulation, these marks are multiplied by a coefficient (K-Factor) which varies with the difficulty of the manoeuvre, usually from one to five.

Any manoeuvre not completed, or flown out of sequence with the stated manoeuvre on the judge's score sheet, shall be scored zero (0). Zero scores need not be unanimous, except in cases where an entirely wrong manoeuvre was performed. Judges must confer after the flight in these cases, bringing it to the attention of the flight line director/contest director on site.

cont/...

Manoeuvres must be performed where they can be seen clearly by the judges. If a judge, for some reason beyond the control of the competitor, is not able to follow the model aircraft through the entire manoeuvre, he may set the "Not Observed" (N.O.) mark. In this case, the scoring tabulators will, as the judge's mark for that particular manoeuvre, enter the average of the numerical marks given by the other judges, rounded to the nearest whole number.

Centre manoeuvres should be performed in the centre of the manoeuvring area while turn around manoeuvres should not extend past a line 60 degrees left and right of centre. Vertical height should not exceed 60 degrees. Also, manoeuvres should be performed along a line of flight approximately 150m in front of the competitor's position. Infractions of this rule will be cause for downgrading by each judge individually and in proportion to the degree of infraction. Exceptions to this rule are for the rolling circle manoeuvres which, of necessity, may deviate from the 150m line of flight.

The manoeuvring area shall be clearly marked with white (or contrasting colour to the background) vertical poles, approximately 100mm in diameter and approximately 4m high, placed on centre and 60 degrees each side of centre on a line 150m in front of the competitor's position. Flags, streamers, or boards of contrasting colour to the background, should be mounted on the poles to improve visibility. White (or contrasting) lines, originating at the competitor's position and extending outward at least 50m, shall also be used to mark the centre and extreme limits (60 degrees left and right of centre) of the manoeuvring zone. Audible and visual signals to indicate violations of the manoeuvring zone must not be used.

The judges shall be seated not more than 10m, and not less than 7m behind the competitor's position (the apex of the 60 degree lines) and within an area described by the extension of the 60 degree lines to the rear of the competitor. The judges must be seated abreast, usually separated by 2m, with scribes or score secretaries separating them. The judges' line is also the zero line, and any part of a manoeuvre performed behind this line, will result in a zero score for that manoeuvre.

At the conclusion of the flight, each judge must independently consider if the in-flight sound level of the model aircraft is too loud. If a majority of the judges consider the in-flight sound level of the model aircraft to be too loud, then the flight score will be penalised by 10 points for each counting judge on that panel during the flight. If, during a flight, the sound level of the model aircraft increases perceptibly as a result of an equipment malfunction, or of a condition initiated by the competitor, the flight line director may request a sound re-test. If an equipment malfunction during the flight (such as mechanical failure of the exhaust/muffler system) causes excessive noise, the flight line director may request the competitor to land his model aircraft, and scoring will cease from the point of malfunction.

If a model aircraft is, in the opinion of the judges, unsafe or being flown in an unsafe manner, they may bring this to the attention of the flight line director, who may instruct the pilot to land.

The individual manoeuvre scores given by each judge for each competitor must be made public at the end of each round of competition. The team manager must be afforded the opportunity to check that the scores on each judge's score sheet correspond to the tabulated scores (to avoid data capture errors). The score board must be located in a prominent position at the flight line, in full view of the competitors and the public.

All preliminary flight results before the completion of a round must be ranked alphabetically, or by country, or by contestant number, but not in order of performance or placing.

5.1.9. **Classification**

For World and Continental Championships, each competitor will have four preliminary (Schedule P) flights, with the best three normalised scores counting to determine the preliminary ranking. All scores, preliminary, semi-final and final, will be normalised to 1000 points as described below. The top one third, but not more than 30 competitors, will then have two additional semi-final flights flying the known finals schedule. The total of the best three preliminary flights (normalised again to 1000 points) will count as one score along with the two semi-finals scores to provide three scores, the best two to count for semi-finals classification.

cont/...

The top ten competitors of the semi-finals of a World or Continental Championship where there was an entry of more than 40 competitors, will then have four additional flights to determine the individual winner. For a World or Continental Championship with less than 40 competitors, the top five competitors will advance to the finals. Two final flights will be the current known finals schedule (F) and two will be unknown schedules (two different schedules, UK1 and UK2) (see 5.5). The known and unknown schedules must be flown in alternating sequence, starting with the known finals schedule (F). The best score from the known schedule will be combined with the best score from the unknown schedules for final classification. In the case of a tie the semi-final score will be used to decide the higher classification.

The team classification is established at the end of the competition (after the finals) by adding the numerical final placing of the three team members of each nation. Teams are ranked from the lowest numerical scores to the highest, with complete three-competitor teams, ahead of two-competitor teams, which in turn are ranked ahead of one-competitor teams. In the case of a tie, the best individual placing decides the team ranking.

For World and Continental Championships, the scores for all rounds, preliminary, semi-finals and finals, will be computed using the Tarasov-Bauer-Long (TBL) statistical averaging scoring system. Only computer tabulation systems containing the TBL algorithm and judge analysis programs that have been approved by the CIAM Bureau can be used at World and Continental Championships.

All scores for each round, preliminary, semi-final and finals, will then be normalised as follows. When all competitors have flown in front of a particular group of judges (ie a round) the highest score shall be awarded 1000 points. The remaining scores for that group of judges are then normalised to a percentage of the 1000 points in the ratio of actual score over winner's score.

$$\text{Points}_x = \frac{S_x}{S_w} \times 1000$$

Points_x = points awarded to competitor X

S_x = score of competitor X

S_w = score of winner of round

Note 1: Final and semi-final flights to determine the individual winner are usually only required for World and Continental Championships. For open international events, national championships, and domestic competitions, the total of the three best preliminary flights may be used to determine the individual winner and team placing. Further flights of Schedule F may be planned, depending on local conditions and time available.

Organisers of Open International and National events may schedule more, or less, than four preliminary rounds/flights, depending on local conditions and time available. In such cases, at least one round/flight should always be able to be discarded to determine the final results. In the event of adverse weather conditions where no further flying is possible, the preliminary classification may be determined as follows:

One round/flight completed by each competitor: round/flight to count

Two rounds/flights completed by each competitor: best round/flight to count

Three rounds/flights completed by each competitor: best two rounds/flights to count

Four rounds/flights completed by each competitor: best three rounds/flights to count.

Note 2: The TBL score tabulation system can only be applied for events with at least 10 competitors and 5 judges. For those smaller events that are not scored with the TBL system, the high and low scores for each manoeuvre will be discarded if four or more judges are used.

5.1.10. Judging

For World Championships the organiser must appoint four panels of five judges each (a total of twenty judges). The judges must be of different nationalities and must be selected from a current list of FAI International Judges. Those selected must reflect the approximate geographical distribution of teams participating in the previous World Championship with the final list approved by the CIAM Bureau. At least one third, but not more than two thirds of the judges must not have judged at the previous World Championships. Judge assignment to the four panels will be by random draw.

cont/...

The invited judges for a World or Continental Championship, must have had a reasonable amount of F3A judging experience of both current P and F schedules, and must submit a résumé of his/her judging experience to the organiser during the nomination process. The organiser must in turn submit the résumés to the CIAM Bureau along with the judges list for approval.

For the semi-final rounds of a World Championship the judges will be arranged in two groups of ten judges. Assignment to the two groups will be by random draw.

For a World Championship with fewer than 72 competitors, and for a Continental Championship with 40 or more competitors, the organiser must appoint two panels of five judges each (a total of ten judges). The judges must be of different nationalities and must be selected from a current list of FAI International Judges. Judge assignment to the two panels will be by random draw.

For Continental Championships with fewer than 30 competitors, the organiser must appoint a single panel of five judges, with the same selection criteria as above.

For World Championships with fewer than 72 competitors, and for a Continental Championships with 30 or more entries, two panels of five judges may be used for the preliminary and semi-final rounds, and one panel of ten judges may be used for the final rounds. For a Continental Championship with fewer than 40 competitors, one panel of five judges may be used for preliminary, semi-final, and final rounds.

For international events where the TBL statistical averaging scoring system is not used, the high and low scores for each manoeuvre may be discarded, but only where four or more judges are used.

For the final rounds of a World Championship with 72 or more competitors, the twenty judges will be arranged in three groups, a left hand group of five judges to judge only the left turn-around manoeuvres, a centre group of ten judges to judge only the centre manoeuvres and a right hand group of five judges to judge only the right turn-around manoeuvres. Judge assignments to the three groups will be by random draw for rounds one and two (one known and one unknown round) with a second draw for rounds three and four, except a judge will not serve in the same group as in the previous draw. For each competitor, the score from the three groups (following TBL computation) will be combined for a total score for the flight.

Before every World Championship, there shall be a briefing for the judges, followed by training flights by non-competitors. Also, warm-up flights for the judges should be flown by non-competitors before the first official preliminary flight each day. For the semi-finals the highest placing non-semi-finalists and for the finals the highest placing two non-finalists should be awarded the honour of performing the warm-up flights. Warm-up flights should be judged but under no circumstances should they be tabulated. Any deviations from the above procedures must be stated in advance by the organisers and must have prior approval of the CIAM or the CIAM Bureau.

5.1.11. **Organisation for Radio Controlled Aerobatics Contests**

For transmitter and frequency control see Section 4B, paragraph B.11.

The draw for flight order will be done for each flight line, so that frequencies are separated with two competitors in between. Team members will not be drawn to fly directly after each other. Team members on separate flight lines will be separated by at least two competitors. Competitor identification numbers will only be assigned after this flight order draw, by pilot group, and in numerical ascending order.

For flights two, three and four of the preliminary rounds the flight order will start $\frac{1}{4}$, $\frac{1}{2}$ and $\frac{3}{4}$ down the flight order respectively. Organisers must take care to avoid a flight draw which will cause competitors to fly at approximately the same time each day.

The flight order for the first semi-finals round will also be by random draw. The second semi-finals flight will start $\frac{1}{2}$ down the semi-finals flight order.

The flight order for the first round of the finals will be established by a random draw as above. The flight order for flights two, three and four will start $\frac{1}{4}$, $\frac{1}{2}$ and $\frac{3}{4}$ down the finals flight order.

During the flight the competitor must stay in the proximity of the judges and under the supervision of the Flight Line Director.

Competitors must be called by a flight line official at least five minutes before they are required to occupy the starting area.

cont/...

If the frequency is clear the competitor or his team manager will be allowed to collect the transmitter from the transmitter pound. The competitor and his helper(s) then occupy the starting area so that a radio check can be performed to verify the correct functioning of the radio control equipment. If there is a frequency conflict, the competitor must be allowed a maximum of one minute for a radio check before the start of the 3 minute starting time.

The time keeper will audibly notify the competitor when the minute is finished and immediately start timing the 3-minutes starting time. Electronic timing displays must be able to be interrupted for the sound/noise test.

A competitor is allowed eight (8) minutes for each flight. The timing of a flight starts when the contest director, or timekeeper, gives an instruction to the competitor to start. The timing device/clock will be interrupted when the competitor is ready to take the sound measurement. Helpers who place the model aircraft, must ensure that the model aircraft is placed in the correct position, as instructed by the officials. When the contest director/sound steward is satisfied that he has obtained a reading from the SLM, he will indicate this to the competitor, and the timing device will be re-activated to continue the timing process. Before the timing device/clock reaches the 3-minute mark, the model aircraft must show a deliberate forward movement for the take-off (throttle advanced). If the model aircraft does not roll forward deliberately before/at the 3-minute-mark, the contest director/time keeper will advise the competitor and helper that the flight may not proceed. The flight shall score zero points. Under normal circumstances, the clock/timing device continues to run, and when reaching the 8-minute mark, the contest director/time keeper will advise the competitor, helper, and the judges, and judging/scoring will stop at that point. The clock will be stopped when the wheels of the model aircraft touch the ground for landing, as proof to the competitor of the recorded time.

No penalty is assigned to the competitor if the expiry of the 8-minute timing period occurs after the last manoeuvre, but before the landing. Thus, the wheels of the model aircraft may touch the ground after the 8-minute mark, with no penalty to the competitor.

The competitor may not start his model aircraft unless he has been instructed by a flight line official to do so. Deliberate starts at the flight line during official flying to check the propulsion device will be subject to disqualification from that round. No public address or commentary should be made during flights.

During the flight, the competitor, and his helper/caller (if required) must stay in the designated position in front of the judges, at the convergence of the ground markings, and under the supervision of the flight line director. The competitor must wear or display his identification/start number.

5.1.12. Execution of Manoeuvres

The manoeuvres must be executed during an uninterrupted flight in the order in which they are listed on the score sheets. The competitor may make only one attempt at each scored manoeuvre during the flight. The competitor has eight minutes to complete the flight; timing to start when the flight line official gives the signal to the competitor to start his model aircraft and ending when the model aircraft first touches the runway after completing the flight.

The model aircraft must take-off and land unassisted, that is, no hand launched flights. If any part of the model aircraft is jettisoned during the flight, scoring will cease at that point and the competitor must be instructed by the flight line director to immediately land his model aircraft. Usually, the judges will be able to determine when a part has been jettisoned from the model aircraft. They should bring this to the attention of the flight line director on site.

Scoring will cease with the expiry of the eight minute time limit, except for the in-flight sound assessment, which is done after the flight is completed, irrespective of the time.

5.1.13. Schedule of Manoeuvres

For 2008-2009, Schedule P-09 will be flown in the preliminaries. Schedule F-09 will be flown in the semi-finals, as well as in the finals, alternating with unknown schedules.

For 2010-2011, Schedule P-11 will be flown in the preliminaries. Schedule F-11 will be flown in the semi-finals, as well as in the finals, alternating with unknown schedules.

cont/...

PRELIMINARY SCHEDULE P-09

K-Factor

Take-off sequence (not judged, not scored)

1. Rev. Split S & Split S Combo, 2/4-pt. roll first, full roll second, inv. exit	4
2. Half reverse cuban 8, two 1/2 rolls in opposite direction	3
3. Three horizontal rolls in opposite direction	4
4. Stall turn, 2/4-pt. roll up, 1/2 roll down	3
5. Top hat, 4/8-pt. roll over top, inverted exit	4
6. Half outside loop	1
7. Triangle loop, with 1/2 rolls in each leg, inverted exit	4
8. Figure 9, two 1/2 rolls in opposite direction on downline	3
9. Stall turn, 3/4 roll up, 1/4 snap roll down.....	5
10.Pull-push-push humpty bump, 1/2 rolls up and down, inverted exit	3
11.Reverse 4-pt. roll (2/4-pt in one direction, 2/4-pt opposite), inverted exit	4
12.Half square loop, full roll up.....	2
13.Two outside loops from top, with fully integrated roll on top	5
14.Two turn spin, inverted exit	3
15.cuban 8, 4/8-pt. roll and full roll in 45 degree downlines.....	4
16.Half square loop on corner, 1/2 rolls 45 degree uplines, inverted exit.....	3
17.45 degrees down, with snap roll, 1/2 roll on exit.....	5
Landing (not judged, not scored)	_____
	60

PRELIMINARY SCHEDULE P-11

K-Factor

Take-off sequence (not judged, not scored)

1. Figure M: 3/4-pt roll up, 1/4 roll down, 1/2 outside loop, integrated 1/2 roll, 1/4 roll up, 3/4 roll down	5
2. Half reverse cuban 8, 2/4-pt roll up.....	3
3. Two slow rolls in opposite direction	3
4. Half square loop, full snap roll up, inverted exit	4
5. 4-pt roll on 45 degrees down, inverted exit.....	3
6. Push-push-pull humpty bump, 1/2 roll up, 2/4-pt roll down.....	3
7. Loop, with 8-pt roll integrated over top 180 degrees	5
8. Half square loop on corner, 2/4-pt rolls, inverted exit	3
9. Reverse cuban 8, 4/8-pt roll and 2/4-pt roll in 45 degree downlines, inverted exit.....	4
10.Half loop with 1/2 roll, inverted entry and exit	2
11.Reverse 8-pt roll (4/8-pt rolls in opposite direction), inverted exit.....	5
12.Stall turn, 2/4-pt roll up, full roll down.....	3
13.Double immelmann, 2/4-pt roll and full roll, inverted exit.....	4
14.Figure 9, full roll up.....	2
15.Opposite knife-edge	5
16.Figure 8, full outside loop, 1/2 loop on top, inverted exit.	2
17.2 1/4 inverted spins in opposite directions, 1/2 roll exit	4
Landing (not judged, not scored)	_____
	60

SEMI- FINALS AND FINALS SCHEDULE F-09**K-Factor**

Take-off sequence (not judged, not scored)	
1. Loop, with full opposite rolls integrated in each 180 degree half	5
2. Stall turn, full snap roll up, 2/4-pt roll down, inverted exit	4
3. Reverse 8-pt roll (4/8-pt rolls in opposite direction), inverted exit.....	4
4. Push-pull-pull humpty bump, 2/4-pt roll up, ½ roll down	3
5. 1 ½ snap roll from knife-edge, inverted exit	5
6. Half square loop, two ½ rolls in upline	3
7. Outside loop, integrated 4-pt roll over bottom 180 degree half.....	5
8. Reverse top hat, ¾ rolls down and up, horizontal cross box inverted, inverted exit.....	3
9. Two turn inverted spin, inverted exit	3
10. Shark fin, two ½ rolls opposite, with 2/4-pt roll in downline, inverted exit	4
11. Triangle loop, two ½ rolls and full roll, inverted exit	4
12. Stall turn 3/4-pt roll up, ¾ roll down	3
13. Knife-edge loop	6
14. Half loop, two opposite full rolls integrated, inverted exit.....	4
15. Horizontal hourglass, knife-edge and full roll in 45 degree uplines, inverted exit.....	5
16. Reverse pull-pull-push humpty bump, 2/4-pt roll down, full roll up, inverted exit.....	4
17. Two opposite snap rolls on 45 degrees down, half roll on exit	5
Landing (not judged, not scored)	_____
	70

SEMI-FINALS AND FINALS SCHEDULE F-11**K-Factor**

Take-off sequence (not judged, not scored)	
1. Top hat, 2/4-pt rolls in up- and downlines, 1½ snap roll over top, inverted exit.....	5
2. Half outside loop, with 1/2 integrated roll, inverted exit	3
3. Square loop on corner, snap rolls in legs 1 & 3, ½ rolls in legs 2 & 4, inverted exit.....	6
4. Figure 6 with 1½ roll down, inverted exit.....	3
5. Inverted rolling circle, with four rolls opposite, first roll to inside, inverted exit	5
6. Stall turn, 2/4-pt roll up, 4-pt roll down	4
7. Snap roll, with 4/8-pt roll opposite, inverted exit	5
8. Shark tooth, 2/4-pt roll up, full roll on 45 degree downline, inverted exit	3
9. Inverted rolling loop, integrated 1/2 rolls opposite in each 180° half, inverted exit.....	5
10. Outside half square loop, 4/8-pt roll up, inverted exit	3
11. Reverse cuban 8, 2/4-pt, 1 ½ snap, and full roll in 45° downlines, inverted exit	5
12. Inverted half cuban 8, 1½ roll down, inverted exit.....	3
13. Snap roll, with 4-pt roll opposite, inverted exit	5
14. Push-pull-push humpty bump, 2/4-pt roll down, inverted exit	3
15. Cobra roll, 1½ snap rolls up and down, inverted exit.....	5
16. Outside immelman turn, 2/4-pt roll, inverted exit.	2
17. Triangle loop, 2/4-pt rolls in 45° down & uplines, snap roll on bottom, ½ roll exit	5
Landing (not judged, not scored)	_____
	70

For the description of the manoeuvres, judging notes, and Aresti diagrams, see Annex 5A.

For the Judges' Guide, see Annex 5B.

ANNEX 5A

F3A - RADIO CONTROLLED AEROBATIC MODEL AIRCRAFT

DESCRIPTION OF MANOEUVRES

5A.1.13 The flight path of a model aircraft is used to judge the shape of all manoeuvres, and manoeuvres must start and finish with straight and level upright or inverted flight of recognisable distance. Centre manoeuvres must start and finish on the same heading, while turn-around manoeuvres must finish on a heading 180 degrees to entry. When appropriate, entry and exit of centre manoeuvres must be at the same altitude, unless specified otherwise. Positioning adjustments in altitude are allowed in turn-around manoeuvres.

All manoeuvres which have more than one loop or parts of loops must have the loops and parts of loops the same diameter/radius and in the case of consecutive loops, in the same place. Similarly, all manoeuvres that have more than one continuous roll must have the same roll rate. All manoeuvres that have more than one point roll, must have the same roll rate, and the points must be of equal duration. Where there is a combination of continuous rolls and point rolls within a manoeuvre, the roll rate for the point rolls does not necessarily have to be the same as the roll rate for the continuous rolls. All consecutive rolls (continuous and/or point rolls, or a combination) on a horizontal line must be at the same altitude and heading.

All manoeuvres with rolls, part rolls, point rolls, or snap-rolls, or combinations of same, must have lines of equal length before and after the rolls or combinations, except when specified otherwise. Barrels rolls and axial rolls instead of specified snap rolls must be downgraded severely (more than 5 points). Snap-rolls may be positive or negative. Spiral dives instead of specified spins must be scored zero. Snap-roll entries to spins must be scored zero. Wing-overs (two wing-spans or more radius of pivot) instead of stall turns must be scored zero.

Any violation of the above will be reason for downgrading. This is in addition to the downgrades for deviations from the manoeuvre descriptions and the judging notes in Annex 5A, the Judges Guide Annex 5B and any official sub-committee-approved judge training material. Note that these lists are not all-inclusive.

Take-off and landing procedures are not judged and are not scored. The direction of landing may be different from that of the take-off.

PRELIMINARY SCHEDULE P-11 (from January 2010)

P-11.01 Figure M, $\frac{3}{4}$ -pt. roll up, $\frac{1}{4}$ roll down, $\frac{1}{2}$ outside loop with integrated $\frac{1}{2}$ roll, $\frac{1}{4}$ roll up, $\frac{3}{4}$ roll down: From upright, pull to a vertical upline and perform a $\frac{3}{4}$ -pt. roll, followed by a stall turn. On the vertical downline, perform a $\frac{1}{4}$ roll. Push through a half outside loop with a fully integrated half roll. On the vertical upline, perform a $\frac{1}{4}$ roll up, followed by a stall turn. On the vertical downline, perform a $\frac{3}{4}$ roll, and pull to exit upright.

P-11.02 Half reverse cuban 8, with $\frac{2}{4}$ -pt. roll up. Pull to a 45 degree upline and perform two points of a four-point roll. Pull through $\frac{5}{8}$ of an inside loop to exit upright.

P-11.03 Two slow rolls in opposite direction: From upright, perform a slow roll, followed by a slow roll in the opposite direction, to exit upright.

Judging notes:

- The pause between rolls is very brief.

P-11.04 Half square loop, snap roll up, inverted exit: From upright, pull to a vertical upline, perform a snap roll, and pull to exit inverted.

P-11.05 4-pt. roll on 45 degrees down, inverted exit: From inverted, pull to a 45 degree inverted downline, perform a 4-pt. roll, and push to exit inverted.

P-11.06 Push-push-pull humpty bump, $\frac{1}{2}$ roll up, $\frac{2}{4}$ -pt. roll down: From inverted, push to a vertical upline and perform a half roll. Push through a half outside loop. On the downline, perform 2 points of a 4-pt. roll, and pull to exit upright.

P-11.07 Loop, with 8-pt. roll integrated over top 180 degrees: From upright, perform an inside loop with a fully integrated 8-pt. roll over the top half of the loop.

Judging notes:

- The 8-pt. roll must be fully integrated on the circular flight path over 180 degrees.

P-11.08 Half square loop on corner, 2/4-pt. rolls, inverted exit: From upright, pull to a 45 degree upline, and perform 2 points of a 4-pt. roll. Push through 90 degrees to a 45 degree upline, perform two points of a 4-pt. roll, and pull to exit inverted.

P-11.09 Reverse cuban 8, 4/8-pt. roll and 2/4-pt. roll in on 45 degree downlines, inverted exit: From inverted, pull to a 45 degree inverted downline, and perform 4 points of an 8-pt. roll. Pull through a $\frac{3}{4}$ inside loop to a 45 degree inverted downline, perform 2 points of a 4-pt. roll, and pull through $\frac{5}{8}$ of an inside loop to exit inverted.

P-11.10 Half loop with $\frac{1}{2}$ roll, inverted exit: From inverted, pull through a half inside loop, followed immediately by a half roll, to exit inverted.

P-11.11 Reverse 8-pt roll (4/8-pt. rolls in opposite direction), inverted exit: From inverted, perform 4 points of an 8-pt roll in one direction, followed by 4 points of an 8-pt. roll in the opposite direction, to exit inverted.

P-11.12 Stall turn, 2/4-pt. roll up, full roll down: From inverted, push to a vertical upline, perform 2 points of a 4-pt. roll, followed by a stall turn. On the vertical downline, perform a roll, and pull to exit upright.

P-11.13 Double immelman, 2/4-pt. roll and full roll, inverted exit: From upright, pull through a half inside loop, followed immediately by 2 points of a 4-pt. roll. Push through a half outside loop, followed immediately by a roll, to exit inverted.

Judging notes:

- The 2/4-pt. roll and full roll must follow immediately after the part-loops.
- The length of the upper and lower horizontal line (including rolls) is equal to the diameter of the half loops.

P-11.14 Figure 9, full roll up: From inverted, push to a vertical upline, and perform a roll. Pull through a $\frac{3}{4}$ inside loop to exit upright.

P-11.15 Opposite knife-edge: From upright, on a horizontal line, perform a $\frac{1}{4}$ roll to knife-edge. Perform a $\frac{1}{2}$ roll in the opposite direction, to knife-edge, and perform a $\frac{1}{4}$ roll to exit upright.

Judging notes:

- The knife-edge segments must be of equal length, and must be long enough to demonstrate controlled, sustained knife-edge flight.

P-11.16 Figure 8, full outside loop, $\frac{1}{2}$ loop on top, inverted exit: From upright, push through an outside loop, followed by a half loop, to exit inverted.

P-11.17 Inverted spin of $2\frac{1}{4}$ turns and $2\frac{1}{4}$ turns in the opposite direction, with $\frac{1}{2}$ roll exit: Perform an inverted spin of $2\frac{1}{4}$ consecutive turns immediately followed by $2\frac{1}{4}$ consecutive turns in the opposite direction. Push through a $\frac{1}{4}$ loop to horizontal, and perform a $\frac{1}{2}$ roll to exit upright.

Judging notes:

- Snap entry, zero points.
- Forced entry, downgrade.
- Turn reversal is immediate.

SEMI-FINALS AND FINALS SCHEDULE F-11 (from January 2010)

F-11.01 Top hat, 2/4-pt. rolls in up- and downlines, 1½ snap roll over top, inverted exit: From upright, pull to a vertical upline and perform 2 points of a 4-pt. roll. Pull to horizontal inverted and perform 1½ snap rolls. Push to a vertical downline, perform 2 points of a 4-pt. roll, and push to exit inverted.

Judging notes:

- The geometric shape of the top hat is square.

F-11.02 Half outside loop, with ½ integrated roll, inverted exit: From inverted, push through a half outside loop with a fully integrated ½ roll, to exit inverted.

F-11.03 Square loop on corner, snap rolls in legs 1 and 3, ½ rolls in legs 2 and 4, inverted exit: From inverted, pull to a 45 degree inverted downline and perform a snap roll. Pull through 90 degrees to a 45 degree downline and perform a ½ roll. Push through 90 degrees to a 45 degree inverted upline and perform a snap roll. Push through 90 degrees to a 45 degree upline, perform a ½ roll, and pull through 45 degrees to exit inverted.

F-11.04 Figure 6, with 1½ rolls down, inverted exit: From inverted, pull to a vertical downline and perform 1½ rolls. Pull through a ¾ inside loop to exit inverted.

F-11.05 Inverted rolling circle, with 4 rolls opposite, first roll to the inside, inverted exit: From inverted, perform a rolling circle (away from, or towards the runway), with four rolls in opposite directions. The first roll is to the inside of the circle. Exit inverted, at the same point as entry.

Judging notes:

- Roll rate must be constant and continuous.
- Roll reversal must be immediate.
- Circle must be of constant radius and wind corrected.
- Manoeuvre must be downgraded if the far side of the circle exceeds approximately 350 m from the safety line. If the competitor chooses to perform the circle towards the runway, the manoeuvre must be downgraded if any portion of the circle is outside of the manoeuvring zone.

F-11.06 Stall turn, 2/4-pt. roll up, 4-pt. roll down: From inverted, push to a vertical upline and perform 2 points of a 4-pt. roll, followed by a stall turn. On the vertical downline, perform a 4-pt. roll, and pull to exit upright.

F-11.07 Snap roll, with 4/8-pt. roll opposite, inverted exit: From upright, perform a snap roll, followed by 4 points of an 8-pt. roll in the opposite direction, to exit inverted.

Judging notes:

- The pause between the snap roll and the opposite part-roll must be very brief.

F-11.08 Shark tooth, 2/4-pt. roll up, roll in 45 degree downline, inverted exit: From inverted, push to a vertical upline, and perform 2 points of a 4-pt. roll. Pull through 135 degrees to a 45 degree inverted downline, perform a full roll, and push to exit inverted.

F-11.09 Inverted rolling loop, integrated ½ rolls opposite in each 180 degree half, inverted exit: From inverted, push through an outside rolling loop, with a fully integrated ½ roll in the first 180 degrees of the loop, and a fully integrated opposite ½ roll in the second 180 degrees of the loop, to exit inverted.

Judging notes:

- Integrated rolls must be in opposite directions.
- Roll reversal must be immediate.

F-11.10 Outside half square loop, 4/8-pt. roll up, inverted exit: From inverted, push to a vertical upline, perform 4 points of an 8-pt. roll, and pull to exit inverted.

F-11.11 Reverse cuban 8, 2/4-pt. roll, 1½ snap rolls, and full roll in 45 degree downlines, inverted exit: From inverted, pull to a 45 degree downline and perform 2 points of a 4-pt. roll. Pull through a ¾ inside loop to a 45 degree downline, and perform 1½ snap rolls. Pull through a ¾ inside loop to a 45 degree downline, perform a full roll, and push to exit inverted.

F-11.12 Inverted half cuban 8, 1½ rolls down, inverted exit: From inverted, push through ¾ of an outside loop to a 45 degree downline. Perform 1½ rolls and push to exit inverted.

F-11.13 Snap roll, with 4-pt. roll opposite, inverted exit: From inverted, perform a snap roll, followed by a 4-pt. roll in the opposite direction, to exit inverted.

Judging notes:

- The pause between the snap roll and the opposite point-roll must be very brief.

F-11.14 Push-pull-push humpty bump, 2/4-pt. roll down, inverted exit: From inverted, push to a vertical upline, and pull through a ½ inside loop. On the vertical downline, perform 2 points of a 4-pt. roll, and push to exit inverted.

F-11.15 Cobra roll, 1½ snap rolls up and down, inverted exit: From inverted, push to a 45 degree inverted upline, and perform 1½ snap rolls. Push through 90 degrees to a 45 degree downline, perform 1½ snap rolls, and push to exit inverted.

Judging notes:

- Snap rolls may be in either direction.

F-11.16 Outside immelman turn, 2/4-pt. roll, inverted exit: From inverted, push through a ½ outside loop, followed immediately by 2 points of a 4-pt. roll, to exit inverted.

Judging notes:

- The 2/4-pt roll must follow immediately after the half outside loop.

F-11.17 Triangle loop, 2/4-pt. rolls in 45 degree down and uplines, snap roll on bottom, ½ roll exit: From inverted, pull through 135 degrees to a 45 degree downline, and perform 2 points of a 4-pt. roll. Pull through 135 degrees to horizontal, and perform a snap roll. Pull through 135 degrees to a 45 degree inverted upline, and perform 2 points of a 4-point roll. Pull through 135 degrees, and perform a ½ roll to exit upright.

The Aresti diagrams appear overleaf.

F3A PRELIMINARY SCHEDULE P-11 (from January 2010)

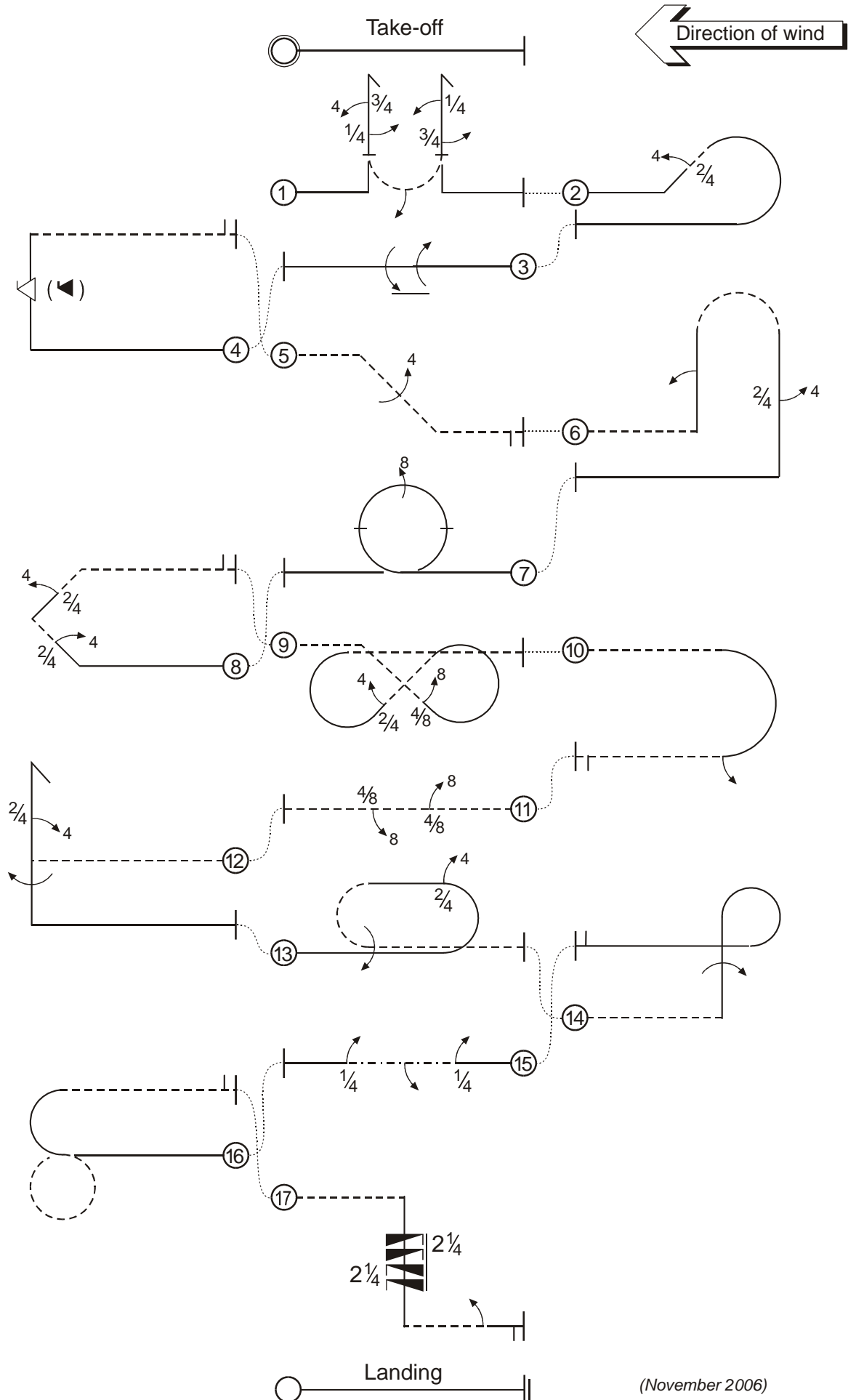

F3A SEMI-FINALS AND FINALS SCHEDULE F-11 (from January 2010)

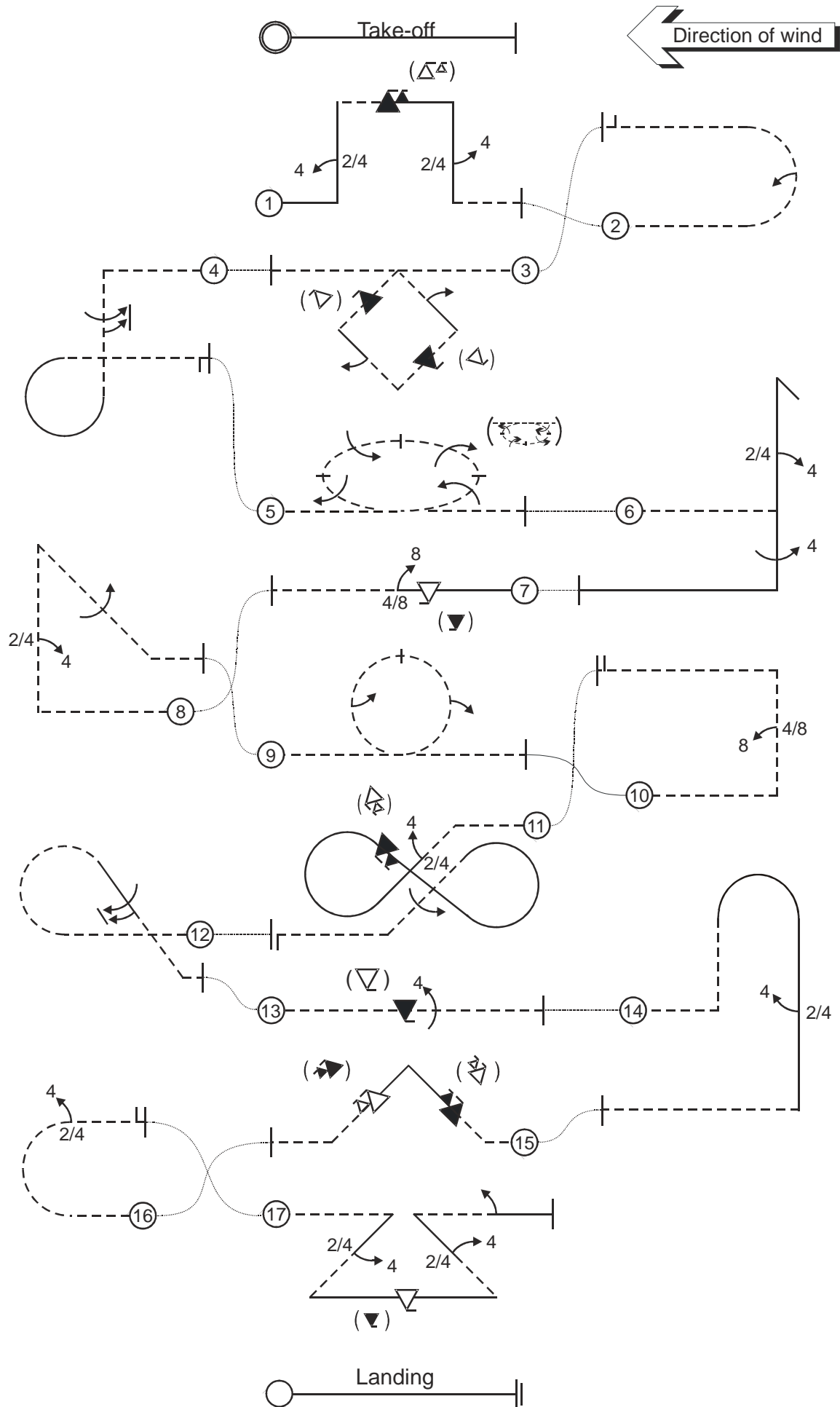

PAGE DELIBERATELY LEFT BLANK

EXPLANATION OF ARESTI SYMBOLS

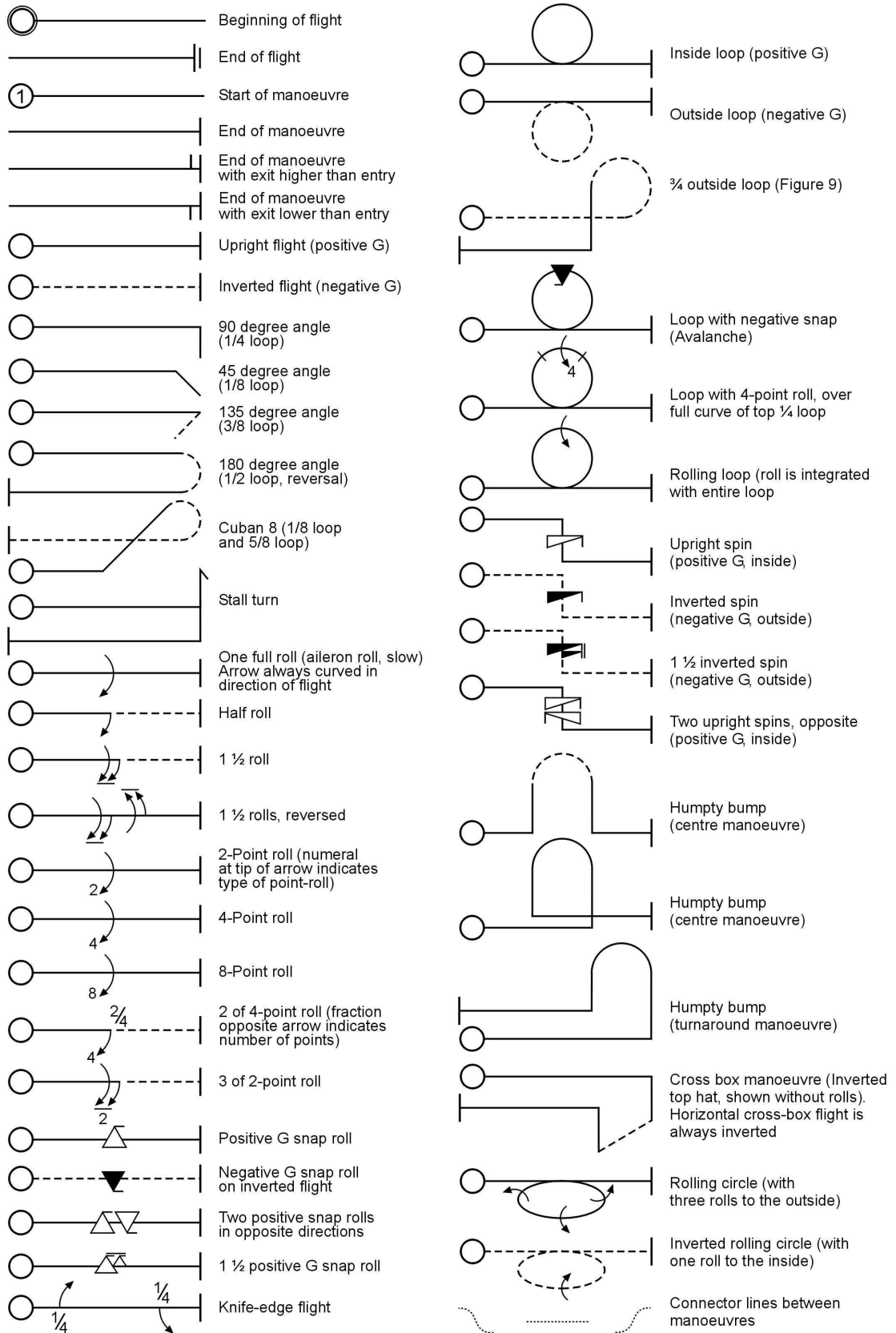

ANNEX 5B

F3A RADIO CONTROLLED AEROBATIC MODEL AIRCRAFT JUDGES' GUIDE

5B.1. PURPOSE

The purpose of the FAI F3A Judges' Guide is to give an accurate description of the major classes of aerobatic manoeuvres and their judging criteria as reference for use in developing a uniformly high, accurate, consistent, and unbiased standard of judging.

5B.2. PRINCIPLES

The principles of judging the performance of a competitor in a R/C Aerobatic competition is based on the perfection with which the competitor's model aircraft executes the aerobatic manoeuvres as described in Annex 5A. The main principles used to judge the degree of perfection are:

1. Precision of the manoeuvre.
2. Smoothness and gracefulness of the manoeuvre.
3. Positioning or display of the manoeuvre.
4. Size of the manoeuvre, relative to the manoeuvring area and other manoeuvres in the flight.

The above requirements are not listed in order of importance, and all of them must be met for a manoeuvre to receive a high score.

5B.3. ACCURATE AND CONSISTENT JUDGING

The most important aspect of consistent judging is for each judge to establish his standard and then maintain that standard throughout the competition. It is advisable for the jury president, in conjunction with the contest director and the championship organiser to hold a conference prior to the start of the competition, in order to discuss judging and make the standards as uniform as possible. This is further augmented by some practice flights which all judges score simultaneously and privately. After these flights, the defects in each manoeuvre should be discussed by all judges and agreement reached about the severity of the defects. Once the contest is started, the individual judge must not alter his standard under any influence.

An accurate standard of judging is also very important. Being a consistent judge, whether high or low, is not good if the scores awarded are not a fair reflection of the manoeuvre performed.

A judge must not, under any circumstances, favour a competitor, or a national team, or a particular flying style, or brand of equipment, or propulsion method. Judges must only look at the lines described in the sky. Conversely, acts of negative bias towards a competitor, or a national team, or a flying style, or brand of equipment, or a propulsion method, must be viewed in a serious light, and corrective action may be necessary.

5B.4. CRITERIA FOR JUDGING MANOEUVRES

In Annex 5A a description of each manoeuvre is given, with judging notes with some manoeuvres. Each manoeuvre must be downgraded according to:

1. The type of defect.
2. The severity of the defect.
3. The number of times any one defect occurs, as well as the total number of defects.
4. The positioning of the manoeuvre.
5. The size of the manoeuvre, relative to the manoeuvring area and relative to other manoeuvres being flown.

A high score should be given only if no major defects are found and the manoeuvre is well positioned. Judges must not allow themselves to be influenced by the performance of the model aircraft, and its propulsion method.

cont/...

5B.5. **ATTITUDE AND FLIGHT PATH**

The flight path of a model aircraft is the trajectory of its centre of gravity. The attitude is the direction of the fuselage centre-line in relation to the flight path.

If not otherwise stated, all judging is based on flight path.

5B.6. **THE 1 POINT/15 DEGREE RULE**

This basic rule provides a general guide for downgrading deviations from defined manoeuvre geometry. One point must be subtracted for each approximate 15 degrees deviation. In general, lines can and must be judged more critically than deviations in yaw or roll.

5B.7. **GRADING CRITERIA FOR THE INDIVIDUAL MANOEUVRES**

These criteria are given to provide judges with a guide for downgrading deviations from the defined manoeuvre geometry. The manoeuvres are divided into their different components: lines, loops, rolls, stall-turns, snap-rolls, spins, loop/roll/line combinations, and rolling circles.

5B.7.1 **LINES**

All aerobatic manoeuvres are started and ended by a horizontal line of recognisable distance. When no horizontal line is flown between two manoeuvres, the just-completed manoeuvre must be downgraded by 1 point, and the upcoming manoeuvre must be downgraded by 1 point. Horizontal flying between manoeuvres which is not considered part of the exit or entry, must be observed, but not judged for quality.

The total length of a vertical or climbing line, as dictated by the performance of the model aircraft, is not a grading criterion. The performance of the model aircraft or its propulsion device, must not be allowed to influence a judge's mark.

All lines within a manoeuvre have a beginning and an end which define their length. They are preceded and followed by part loops. The length of a line should only be graded when a manoeuvre contains several lines with a given relationship, as in a square loop. If there is a minor mis-relation, 1 point is subtracted, and more points are subtracted for greater defects.

Whenever a type of roll or snap roll is placed on a line, the length of the line before and after the roll must be equal, except where there is no relation of the line with other elements in the manoeuvre (example: immelman turn). One point is subtracted for a reasonable difference, and two points for a greater difference. If there is a complete absence of a line before or after the roll, 3 points are subtracted.

5B.7.2. **LOOPS**

A loop must have, by definition, a constant radius, and must be flown in the vertical plane throughout. It starts and ends by a well defined line which, for a complete loop, is horizontal. For a part-loop, however, such lines may be in any other plane of flight as required by the particular manoeuvre being flown.

The loops and part-loops within one manoeuvre must have the same radius. Each occurrence of a slight difference in radius must downgrade the manoeuvre by 1 point, while more severe differences may downgrade it by 2 or 3 points for each occurrence. The radius of the first loop or part-loop, determines the radii of subsequent loops or part-loops within a manoeuvre.

Every loop or part-loop must be flown without interruption to the circular flight path. Every visible segmentation must be downgraded by 1 point.

If the loop is not flown entirely in the vertical plane, ie it drifts closer or further from the judges, minor drift must be downgraded by 1 point, while more severe drift must be downgraded by several points.

In three-, four-, six-, and eight-sided loops, higher marks must not be awarded for flying tight, high G corners. The main criteria are that the loop must have the sides at the correct angles for the defined number of times, and all part-loops must have the same radius.

5B.7.3. **ROLLS**

Rolls and part-rolls may be flown as individual manoeuvres, or as parts of other manoeuvres. The following criteria apply to all rolls:

- a) The rate of roll must be constant. Small variations in roll-rate must be downgraded by 1 point, while more severe variations must receive heavier downgrades. Slowing down (or speeding up) the roll rate towards the end of a roll must be downgraded using the 1 point/15 degree rule.

cont/...

- b) The roll must have a crisp and well-defined start and stop. If a start or stop is badly defined, 1 point is subtracted for each.
- c) Except where mentioned otherwise, all rolls flown on lines between part-loops must be placed on the middle of that line. For downgrading, see 4.3.1.
- d) Point-rolls within a manoeuvre must have the same roll rate, and the points must be of equal duration on each point. One point is subtracted for slight variations, while more severe mis-timing is further downgraded. If points are not visible or badly-defined during a point roll, or there are more than the required number of points, the manoeuvre is downgraded using the 1 point/15 degree rule.

5B.7.4. **STALL-TURNS**

The criteria in this manoeuvre are mainly about lines. The lines must have exactly vertical and horizontal flight paths.

The model aircraft must pivot around its centre of gravity, in the yaw axis, for the manoeuvre to receive a high score. If the model aircraft does not pivot on the CG, but within a radius of 1/2 wingspan, one point is subtracted. For a radius of pivot up to one wingspan, 2 points are subtracted, and if the radius exceeds 1½ wingspan, the manoeuvre is severely downgraded. A radius of pivot of 2 wingspans or more is considered a wing-over and a zero score must be awarded. If the model aircraft should “torque-off” during the stall turn, a downgrade must be applied using the 1-point/15 degree rule. If the model aircraft flops forward or backward in a stall turn, a zero score must be awarded.

If the model aircraft shows a pendulum movement after the pivot, the manoeuvre is downgraded by one point. Similarly, if the model aircraft should “skid” before reaching the stall turn (early application of rudder), the manoeuvre is downgraded by one point. Drift of the model aircraft during the stalled condition must be ignored, provided the model aircraft does not drift outside the aerobatic zone.

The entry and exit must consist of part-loops with constant and equal radii.

Any types of rolls must be placed on the middle of the lines. The length of the vertical lines is not a judging criterion.

5B.7.5. **SNAP-ROLLS**

A snap-roll (or flick roll/rudder roll) is a rapid autorotative roll where the model aircraft is in a stalled attitude, with a continuous high angle of attack

Snap-rolls have the same judging criteria as axial rolls as far as start and stop of the rotation, and constant flight path through the manoeuvre is concerned.

At the start of a snap-roll, the fuselage attitude must show a definite break and separation from the flight path, before the rotation is started, since the model aircraft is supposed to be in a stalled condition throughout the manoeuvre. If the stall/break does not occur and the model aircraft barrel-rolls around, the manoeuvre must be severely downgraded (more than 5 points). Similarly, axial rolls disguised as snap-rolls must be severely downgraded (more than 5 points).

Snap-rolls can be flown both positive and negative, and the same criteria apply. The attitude (positive or negative) is at the competitor’s discretion. If the model aircraft returns to an unstalled condition during the snap-roll, the manoeuvre is severely downgraded using the 1 point/15 degree rule.

5B.7.6. **SPINS**

All spins begin and end with horizontal lines. In order to spin, the model aircraft must be stalled. The entry is flown in a horizontal flight path with the nose-up attitude increasing as the speed decreases. Drift of the model aircraft from the flight path at this point should not be downgraded, since it is in a near-stalled condition. However, severe yawing or weathercocking during the near-stalled condition, should be downgraded by 1 point/15 degrees. A climbing flight path just prior to the spin must be downgraded, using the 1-point/15 degree rule. The nose then drops as the model aircraft stalls. Simultaneously as the nose drops, the wing also drops in the direction of the spin. Drift during the rotation of the spin should not be downgraded since the model aircraft is in a stalled condition, provided the model aircraft does not drift outside the aerobatic zone.

If the model aircraft does not stall or if the model aircraft is snap-rolled into the spin, the manoeuvre is zeroed. If the model aircraft slides into the spin (is loath to spin), the manoeuvre must be downgraded by using the 1/point per 15 degree rule. Forcing the model aircraft to spin in the opposite direction as the initial rotation must be severely downgraded. Forcing the model aircraft to spin from a high angle of attack with down (or up) elevator, should be downgraded by 4 or 5 points. Judges must carefully observe the

stalled attitude, which is not necessarily a complete stop, especially in no-wind conditions. This is no reason for downgrading.

After the defined number of turns, the stop of rotation is judged in the same manner as for a roll, ie one point downgrade for each 15 degree deviation of heading. The spin rotation should stop parallel to the flight line. "Unloading", or stopping the spin rotation early and then applying only aileron to roll the model aircraft to the desired attitude, should be downgraded using the 1 point/15 degree rule.

A vertical downward line of visible length must be held after the rotation stops. The pull- or push-out is judged like a part-loop and if followed by a part-roll, should be separated by a well-defined segment of straight flight. Remember that different models spin in different attitudes, and that the attitude is not to be taken into consideration, as long as the model aircraft is stalled. Any reversals in direction must be immediate, and if the model aircraft returns to an unstalled condition during the spin, the manoeuvre is severely downgraded. The rate of rotation during a reversed spin may be slightly different, without a downgrade, but if the difference is significant, one point is subtracted.

5B.7.7 LOOP/ROLL COMBINATIONS

These combinations are used extensively in centre manoeuvres turn-around manoeuvres. They are very diversified, but all are combinations of loops, part-loops, rolls, point-rolls, part rolls, snap-rolls and lines. All judging criteria for these apply.

There are, however, some judging criteria which should be explained further. In the Immelmann turn and split S manoeuvres and variations, the half roll, snap-roll, point-roll, or full roll should be performed immediately after or before the half loop as required by the particular manoeuvre. A visible line in between the two components must downgrade the manoeuvre by 2 points. Similarly, if the half roll, snap-roll, point-roll, or full roll is performed too early, the manoeuvre should be downgraded, using the 1 point/15 degree rule.

On half cuban eights and half reverse cuban eights, the roll, point-roll, or snap roll should be placed on the middle of the line. The radii of the part-loops must all be the same.

In humpty-bumps, the radius of the part-loop on the top (or bottom) and the exit part-loop must be constant, and be the same as that of the entry part-loop. Falling forward (or tight radius) must be downgraded.

Rolls or part-rolls that are integrated with loops, should be smooth, continuous, and of constant radius. Quick-rolling where an integrated roll is required, should be downgraded, using the 1 point/15 degree rule.

5B.7.8. ROLLING CIRCLES

Rolling circles are mostly used as centre manoeuvres, and may be performed at a high or low altitude. The criteria for rolling circles are mainly about the circular flight path, constant altitude of the circle, constant rates of roll, and integration of the rolls or part-rolls with the circle.

The circular flight path should be maintained throughout the manoeuvre, and there must be no deviation in altitude. At low level it may be more difficult for judges to determine the roundness of the circle. The 150m distance requirement is waived for rolling circles, and a downgrade should only be applied if the far side of the circle exceeds approximately 350 metres. Deviations from geometry should be downgraded using the 1 point/15 degree rule.

Rolls or part-rolls on the circular flight path must be continuous and have a constant rate of rotation, and must be correctly positioned. Small variations in roll-rate must be downgraded by 1 point, while more severe variations must receive heavier downgrades. Slowing down, or speeding up the roll rate towards the end of a roll to ensure correct geometry must be downgraded using the 1 point/15 degree rule. The rolls or part-rolls must have a crisp and well-defined start and stop. If a start or stop is badly defined, 1 point is subtracted for each. Any roll reversals should be immediate. Judges should pay particular attention where the manoeuvre description requires a roll or part rolls to be performed to the inside or the outside of the circle. For a roll or part-roll performed in the wrong direction, a zero score must be awarded.

Depending on the distance from the competitor at the entry, rolling circles may be performed away from or towards the judges, and are at the competitor's discretion.

cont/...

5B.7.9. TAKE-OFF AND LANDING

Take-off.

The take-off procedure is not judged and not scored.

Landing

The landing procedure is not judged, and not scored. Timing of the flight ends when the model aircraft first touches the landing area.

5B.8. WIND CORRECTION

All manoeuvres are required to be wind corrected in such a way that the shape of the manoeuvre as described in Annex 5A. is preserved in the model aircraft's flight path. The exceptions to this grading criterion are in the stall turns, and spins, where the model aircraft is in a stalled condition.

5B.9. POSITIONING

The entire flight must be within the aerobatic zone to avoid being penalised. A centre manoeuvre must be flown so that it is centred on the centre line and the centre flag. If the manoeuvre is flown off-centre, it must be downgraded according to the misplacement. This may be in the range of 1 to 4 points subtracted.

If an entire manoeuvre including entry and exit is flown out of the aerobatic zone, it must be zeroed. Downgrades for flying a manoeuvre partially out of the zone should be in proportion to the degree of infraction, ie a small part of the manoeuvre (10%) flown past the 60 degree line would call for a minor downgrade (10%), perhaps one point, while more of the manoeuvre (say 30% or 40%) flown past the 60 degree line must be downgraded more severely (30% or 40%), say three or more points. Also, violations of the 60 degree line that occur near the 150 metre line (ie approximately over the 60 degree flags) should be downgraded less severely than violations along a line further out and more distant from the judges.

Vertical height should not exceed 60 degrees and downgrades for flying a manoeuvre partially out of the zone should be in proportion to the degree of infraction as stated above.

Flying so far out as to make evaluation of a manoeuvre difficult should be severely downgraded. The main criterion here is *visibility*. For a large, highly visible model aircraft, a line of flight approximately 175m in front of the pilot may be appropriate, while a smaller less visible model aircraft might have to be flown at say 140 to 150m. Manoeuvres performed on a line greater than approximately 175m in front of the competitor must be downgraded by at least one point.. Manoeuvres performed on a line greater than 200m in front of the competitor must be downgraded more severely (in the order of 2 to 3 points).

In general, turn-around manoeuvres are positioning manoeuvres. Therefore, entry and exit altitude need not be the same if the pilot wishes to make an altitude adjustment.

Any part of any manoeuvre which is performed beyond the zero line, will be justification for a zero score for that manoeuvre. Repeated infringements of the zero line may result in the competitor being asked by the flight line director to terminate the flight, due to safety reasons.

5B.10. EXAMPLES

An avalanche is entered in a slight climb, the flight path turns 15 degrees to one side after the snap and a wing is 15 degrees low during the exit. $10 - 1 - 1 - 1 = 7$ points.

A 4-point roll is started late and ends up slightly off-centre and there is no pause to define the third point. $10 - 2 - 6$ (1 point per 15 degrees) = 2 points.

An 8-point roll is started late and ends up slightly off-centre, and there is no pause to define the second point. $10 - 2 - 3 = 5$ points.

An Immelmann turn is not well-rounded, the half roll is started before the model aircraft reaches the top of the loop, with the wing 15 degrees low and the flight path of the model aircraft 20 degrees off heading. $10 - 1 - 2 - 1 - 2 = 4$ points.

A snap-roll on a 45 degree downline appears to be nothing more than an axial roll with a wiggle of the tail of the model aircraft. All other components are perfect. $10 - 6 = 4$ points.

During a humpty bump, a snap roll on a vertical downline appears to be a barrel roll, and the exit radius is noticeably smaller in radius than the other two part-loops. $10 - 6 - 1 = 3$ points.

cont/...

A square loop with half rolls has the first leg climbing 100 degrees. The model aircraft gallops in elevation across the top, stops the vertical downward half roll 15 degrees too early, is corrected, and the last half roll ends up 10 degrees to one side of the centre-line. $10 - 1 - 2 - 1 - 1 = 5$ points.

On a top hat with $\frac{1}{4}$ rolls, the model aircraft is accidentally rolled in the wrong direction and the horizontal flight is performed upright instead of inverted. $10 - 10 = 0$ points.

In the middle of a double Immelmann, which may be manoeuvre number 12, a competitor experiences an engine cut and the manoeuvre is not completed. $10 - 10 = 0$ points. The rest of the manoeuvres are also awarded zero points.

An otherwise flawless two-turn spin is about 45 degrees off-centre. This must be considered as a severe misplacement. $10 - 4 = 6$ points.

During a stall turn in dead-calm conditions, the flight path of the model aircraft is exactly vertical, but the model aircraft is "skidded" 15% in the upline to ensure a turn. The model aircraft shows a pendulum movement after the stall turn, and the half roll in the downline is performed directly before the part-loop exit. $10 - 1 - 1 - 3 = 5$ points.

A loop with an integrated roll on top has the roll performed rapidly with no attempt by the competitor to integrate the roll with the top 90 degree quadrant of the loop. $10 - 6 = 4$ points.

A half reverse cuban eight is started too late, and the pilot squeezes the manoeuvre together by flying a 60 degree upline and making no line after the half roll. The manoeuvre still gets about halfway (50%) out of the zone. $10 - 1 - 3 - 5$ (misplacement, going out of the zone) = 1 point.

During an inverted spin entered flawlessly, the model aircraft unstalls and makes the final 90 degree of rotation as a vertical axial roll. $10 - 6 = 4$ points.

A competitor flies a flawless 8-point roll. $10 - 0 = 10$ points. You will not see too many of these in a competition but a manoeuvre should be awarded a 10 if there are no detectable flaws that would otherwise downgrade it to a 9.

A competitor performs a near-perfect split-S, and the only flaw is a very slight, barely visible low wing on exit. $10 - 0 = 10$ points. In some cases, an error may be so slight that a judge may want to consider giving a score of 10, rather than wait for the perfect manoeuvre to arrive.

A competitor performs a manoeuvre other than that stated on the score sheet. $10 - 10 = 0$ points.

After this incident, the competitor performs the rest of the manoeuvres out of sequence, and no manoeuvres correspond to the manoeuvres stated on the score sheet, in the order in which they are listed. All manoeuvres affected in this way score 0 points.

During a figure M, the model aircraft disappears from view behind a low cloud, or in the sun, which is directly in the background, so that only one stall turn is visible. Score = N/O. The competitor will be awarded a reflight with the entire schedule being judged, but only the score for the affected manoeuvre used to complete the tabulation.

During an avalanche, a judge fails to notice the snap-roll at the top of the manoeuvre. Score = N/O. The score tabulators will enter the numerical average of the other judges' scores, rounded to the nearest whole number.

After the last flying manoeuvre in a preliminary schedule, an official calls "time". The competitor lands his aircraft after expiry of the time limit. No penalty.

ANNEX 5G

F3A RADIO CONTROLLED AEROBATIC MODEL AIRCRAFT UNKNOWN MANOEUVRE SCHEDULES FOR FINAL FLIGHTS

- 5G.1. Unknown manoeuvre schedules shall be used in two of the four final flights for world or continental championships and shall be composed by the finalists. The composition of any unknown schedule shall be completed no less than 12 hours before the commencement of finals flights for unknown schedules.
- 5G.2. The composition of the unknown manoeuvre schedules shall be done by the finalists with each finalist nominating, in turn, an appropriate centre or turn-around manoeuvre from the approved and published list of manoeuvres. This nomination and selection of manoeuvres may be either manual or computer-aided. The order of selection will be determined following the random flight draw with the order repeating until the manoeuvre schedule is complete. The nominated and selected manoeuvres must conform to the following general criteria:
1. The entry of one manoeuvre must be matched to the exit of the previous manoeuvre, for entry altitude, entry attitude (level upright or level inverted flight), size of manoeuvres (wide as in a horizontal eight or narrow as in a stall turn) and direction of flight.
 2. No duplication of manoeuvres.
 3. No duplication of centre manoeuvres from the same manoeuvre group but excluding group 23 manoeuvres.
 4. Spins are entered into the wind.
 5. All horizontal rolling manoeuvres (4 pt. rolls, 8 pt. rolls, slow rolls, etc) are usually flown in a downwind direction.
 6. Snap rolls may be flown positive or negative, unless specified.
 7. Not more than five manoeuvres of each schedule may be K = 5.
 8. Only 17 manoeuvres per unknown schedule.
 - a) Take-off sequence into wind (not judged and not scored).
 - b) 9 centre manoeuvres (5 upwind, 4 downwind).
 - c) 8 turn-around manoeuvres (4 left and 4 right).
 - d) Landing sequence into wind (not judged and not scored).
 9. There is no limit on the total K-factor, and the maximum score.
- 5G.3. Once an unknown schedule has been composed and checked for correctness it must receive the final approval of the Jury and the contest director. Printed copies, showing the Aresti pictograms and manoeuvre lists, shall then be distributed to team managers, finalists, judges, jury members, and non-finalists who are scheduled to perform warm-up flights. A sufficient number shall be made available by the organisers for spectators.
- 5G.4. The judges shall receive instructions after the composition of the unknown schedule covering the unknown manoeuvres to ensure that they are fully aware of the sequence of manoeuvres.
- 5G.5. Aresti drawings of the unknown schedules must be provided to finalists and judges.
- 5G.6. Finalists may not attempt practice flights of an unknown schedule between its composition and the finals flights either with a model aircraft or via electronic flight simulator. Evidence of such practice shall be deemed cheating and shall lead to disqualification from the championships. Hand-held stick models are permitted.
- 5G.7. In addition to the warm-up flight for the finals known schedule, at least two warm-up flights must be arranged for the unknown schedule. The unknown warm-up flights may be observed by the finalists and must be judged. Under no circumstances should the flight scores of any warm-up flights be tabulated.

cont/...

5G.8. List of manoeuvres for composition of unknown schedules

5G.8.1. Centre manoeuvres

(Only one manoeuvre from each number group per schedule)

- 1.1 Rolling loop with one roll (from bottom) (K5)
- 1.2 Rolling loop with one roll (from bottom) inverted entry (K5)
- 1.3 Loop with 8-point roll (from bottom) (K5)
- 1.4 Loop with 8-point roll (from bottom) inverted entry (K5)
- 1.5 Loop with 4-point roll (from bottom) (K5)
- 1.6 Loop with 4-point roll (from bottom) inverted entry (K5)
- 2.1 Two loops with half rolls at top (from bottom) (K3)
- 2.2 Two loops with half rolls at top (from bottom) inverted entry (K4)
- 2.3 Two loops with half rolls at bottom (from top) (K4)
- 2.4 Two loops with half rolls at bottom (from top) inverted entry (K3)
- 2.5 Two loops with full roll first top, half roll second (from bottom) (K4)
- 2.6 Two loops with full roll first top, half roll second, inverted entry (from bottom) (K4)
- 2.7 Two loops with half roll first top, full roll second (from bottom) (K4)
- 2.8 Two loops with half roll first top, full roll second, inverted entry (from bottom) (K4)
- 2.9 Two loops with full roll first bottom, half roll second (from top) (K4)
- 2.10 Two loops with full roll first bottom, half roll second (from top) inverted entry (K4)
- 2.11 Two loops with half roll first bottom, full roll second (from top) (K4)
- 2.12 Two loops with half roll first bottom, full roll second (from top) inverted entry (K4)
- 3.1 Avalanche with full snap (from bottom) (K3)
- 3.2 Avalanche with full snap (from bottom) inverted entry (K3)
- 3.3 Avalanche with 1½ snap (from bottom) (K4)
- 3.4 Avalanche with 1½ snap, inverted entry (from bottom) (K4)
- 3.5 Avalanche with 1 negative snap (from top) (K4)
- 3.6 Avalanche with 1 positive snap (from top) inverted entry (K3)
- 4.1 Triangular loop with full roll (from bottom) (K4)
- 4.2 Triangular loop with full roll (from bottom) inverted entry (K4)
- 4.3 Triangular loop with 2/2pt roll (from bottom) (K4)
- 4.4 Triangular loop with 2/2pt roll (from bottom) inverted entry (K4)
- 4.5 Triangular loop with 2/4pt roll (from bottom) (K4)
- 4.6 Triangular loop with 2/4pt roll (from bottom) inverted entry (K4)
- 4.7 Triangular loop with snap roll (from bottom) (K4)
- 4.8 Triangular loop with snap roll (from bottom) inverted entry (K4)
- 4.9 Triangular loop with 1½ snap roll (from bottom) (K4)
- 4.10 Triangular loop with 1½ snap roll (from bottom) inverted entry (K4)
- 4.11 Triangular loop with 1/2 rolls (from bottom) (K3)
- 4.12 Triangular loop with 1/2 rolls (from bottom) inverted entry (K3)
- 4.13 Triangular loop (base at bottom) with half rolls in 45 degree legs (K3)
- 4.14 Triangular loop (base at bottom) with half rolls in 45 degree legs, inverted entry (K3)
- 4.15 Triangular loop (base at bottom) with 2/4pt rolls in 45 degree legs (K4)
- 4.16 Triangular loop (base at bottom) with 2/4pt rolls in 45 degree legs, inverted entry (K4)
- 4.17 Triangular loop (base at bottom) with 2/2pt rolls in 45 degree legs (K4)
- 4.18 Triangular loop (base at bottom) with 2/2pt rolls in 45 degree legs, inverted entry (K4)
- 4.19 Triangular loop from top (base at top) with half rolls in 45 degree legs (K4)
- 4.20 Triangular loop from top (base at top) with half rolls in 45 degree legs, inverted entry (K4)
- 4.21 Triangular loop from top (base at top) with 2/4pt rolls in 45 degree legs (K4)
- 4.22 Triangular loop from top (base at top) with 2/4pt rolls in 45 degree legs, inverted entry (K4)
- 4.23 Triangular loop from top (base at bottom) with half rolls in 45 degree legs (K4)
- 4.24 Triangular loop from top (base at bottom) with half rolls in 45 degree legs, inverted entry (K4)
- 4.25 Triangular loop from top (base at bottom) with 2/4pt rolls in 45 degree legs (K4)
- 4.26 Triangular loop from top (base at bottom) with 2/4pt rolls in 45 legs, inverted entry (K4)
- 4.27 Triangular loop from top (base at bottom) with 2/4pt roll at bottom (K4)
- 4.28 Triangular loop from top (base at bottom) with 2/4pt roll at bottom, inverted entry (K4)
- 4.29 Triangular loop from top (base at bottom) with full roll (K4)
- 4.30 Triangular loop from top (base at bottom) with full roll, inverted entry (K4)
- 5.1 Square loop with half rolls (K5)
- 5.2 Square loop with half rolls, inverted entry (K5)
- 5.3 Square loop with 2/4pt rolls (K5)
- 5.4 Square loop with 2/4pt rolls, inverted entry (K5)

cont/...

- 5.5 Square loop with full snap over top (K4)
- 5.6 Square loop with full snap over top, inverted entry (K4)
- 5.7 Square loop from top with half rolls (K5)
- 5.8 Square loop from top with half rolls, inverted entry (K5)
- 5.9 Square loop from top with 2/4pt rolls (K5)
- 5.10 Square loop from top with 2/4pt rolls, inverted entry (K5)
- 5.11 Square loop from top with full snap at bottom (K4)
- 5.12 Square loop from top with full snap at bottom, inverted entry (K4)
- 6.1 Square loop on corner (K3)
- 6.2 Square loop on corner, inverted entry (K3)
- 6.3 Square loop on corner with half rolls in legs 1 & 3 (K4)
- 6.4 Square loop on corner with half rolls in legs 1 & 3, inverted entry (K4)
- 6.5 Square loop on corner with full roll in leg 1, half roll in leg 3 (K4)
- 6.6 Square loop on corner with full roll in leg 1, half roll in leg 3, inverted entry (K4)
- 6.7 Square loop on corner with four half rolls (K5)
- 6.8 Square loop on corner with four half rolls, inverted entry (K5)
- 6.9 Square loop on corner from top (K3)
- 6.10 Square loop on corner from top , inverted entry (K3)
- 6.11 Square loop on corner from top with half rolls in legs 1 & 3 (K4)
- 6.12 Square loop on corner from top with half rolls in legs 1 & 3, inverted entry (K4)
- 6.13 Square loop on corner from top with full roll in leg 1, half roll in leg 3 (K4)
- 6.14 Square loop on corner from top with full roll in leg 1, half roll in leg 3, inverted entry (K4)
- 6.15 Square loop on corner from top with four half rolls (K5)
- 6.16 Square loop on corner from top with four half rolls, inverted entry (K5)
- 7.1 Six sided loop (K4)
- 7.2 Six sided loop, inverted entry (K4)
- 7.3 Six sided loop from top (K4)
- 7.4 Six sided loop from top , inverted entry (K4)
- 8.1 Cobra roll with 2/4pt rolls (K3)
- 8.2 Cobra roll with 2/4pt rolls, inverted entry (K3)
- 8.3 Cobra roll with 2/2pt rolls (K3)
- 8.4 Cobra roll with 2/2pt rolls, inverted entry (K)3
- 8.5 Cobra roll from top with half rolls (K3)
- 8.6 Cobra roll from top with half rolls, inverted entry (K3)
- 8.7 Cobra roll from top with 2/4pt rolls (K3)
- 8.8 Cobra roll from top with 2/4pt rolls, inverted entry (K3)
- 8.9 Cobra roll from top with 2/2pt rolls (K3)
- 8.10 Cobra roll from top with 2/2pt rolls, inverted entry (K3)
- 9.1 Golf ball (45 degrees up, 3/4 inside loop, 45 degrees down, pull to level), (K3)
- 9.2 Golf ball, inverted entry (K3)
- 9.3 Golf ball with half rolls (K3)
- 9.4 Golf ball with half rolls, inverted entry (K3)
- 9.5 Golf ball with 2/4pt rolls (K3)
- 9.6 Golf ball with 2/4pt rolls, inverted entry (K3)
- 10.1 Cuban eight with 2/4pt rolls (K3)
- 10.2 Cuban eight with 2/4pt rolls, inverted entry (K3)
- 10.3 Cuban eight with full rolls (K4)
- 10.4 Cuban eight with full rolls, inverted entry (K4)
- 10.5 Reverse cuban eight (from bottom) with 2/4pt rolls (K4)
- 10.6 Reverse cuban eight (from bottom) with 2/4pt rolls, inverted entry (K4)
- 10.7 Reverse cuban eight (from bottom) with full rolls (K4)
- 10.8 Reverse cuban eight (from bottom) with full rolls, inverted entry (K4)
- 10.9 Cuban eight from top with half rolls (K3)
- 10.10 Cuban eight from top with half rolls, inverted entry (K3)
- 10.11 Cuban eight from top with 2/4pt rolls (K4)
- 10.12 Cuban eight from top with 2/4pt rolls, inverted entry (K4)
- 10.13 Cuban eight from top with full rolls (K4)
- 10.14 Cuban eight from top with full rolls, inverted entry (K4)
- 10.15 Reverse cuban eight from top with half rolls (K3)
- 10.16 Reverse cuban eight from top with half rolls, inverted entry (K3)
- 10.17 Reverse cuban eight from top with 2/4pt rolls (K4)
- 10.18 Reverse cuban eight from top with 2/4pt rolls, inverted entry (K4)
- 10.19 Reverse cuban eight from top with full rolls (K4)
- 10.20 Reverse cuban eight from top with full rolls, inverted entry (K4)

cont/...

- 11.1 45 degree down with full snap roll (K3)
- 11.2 45 degree down with full snap roll, inverted entry (K3)
- 11.3 45 degree down with 1½ snap roll (K3)
- 11.4 45 degree down with 1½ snap roll, inverted entry (K3)
- 11.5 45 degree down with two 2/4 pt rolls reversed (K4)
- 11.6 45 degree down with two 2/4 pt. rolls reversed, inverted entry (K4)
- 11.7 45 degree down with two 4/8 pt. rolls reversed (K4)
- 11.8 45 degree down with two 4/8 pt. rolls reversed, inverted entry (K4)
- 11.9 45 degree up with 1½ snap roll (K4)
- 11.10 45 degree up with 1½ snap roll, inverted entry (K4)
- 11.11 45 degree up with full snap roll (K3)
- 11.12 45 degree up with full snap roll, inverted entry (K3)
- 11.13 45 degree up with two 2/4 pt rolls reversed (K4)
- 11.14 45 degree up with two 2/4 pt rolls reversed, inverted entry (K4)
- 11.15 45 degree up with two 4/8 pt rolls reversed (K4)
- 11.16 45 degree up with two 4/8 pt rolls reversed, inverted entry (K4)
- 12.1 Figure Z with half roll up (K3)
- 12.2 Figure Z with half roll up, inverted entry (K3)
- 12.3 Figure Z with 2/4pt roll up (K4)
- 12.4 Figure Z with 2/4pt roll up, inverted entry (K4)
- 12.5 Figure Z with 2/2pt roll up (K4)
- 12.6 Figure Z with 2/2pt roll up, inverted entry (K4)
- 12.7 Figure Z from top with half roll down (K3)
- 12.8 Figure Z from top with half roll down, inverted entry (K3)
- 12.9 Figure Z from top with 2/4pt roll down (K4)
- 12.10 Figure Z from top with 2/4pt roll down, inverted entry (K4)
- 12.11 Figure Z from top with 2/2pt roll (K4)
- 12.12 Figure Z from top with 2/2pt roll, inverted entry (K4)
- 13.1 Hourglass (K4)
- 13.2 Hourglass, inverted entry (K4)
- 13.3 Hourglass with half rolls up and down (K4)
- 13.4 Hourglass with half rolls up and down, inverted entry (K5)
- 13.5 Hourglass with 2/4pt rolls up and down (K5)
- 13.6 Hourglass with 2/4pt rolls up and down, inverted entry (K5)
- 13.7 Hourglass (middle entry, top first) (K4)
- 13.8 Hourglass (middle entry, top first) inverted entry (K4)
- 13.9 Hourglass (middle entry, top first), half roll down (K4_)
- 13.10 Hourglass (middle entry, top first) half roll down, inverted entry (K4)
- 13.11 Hourglass (middle entry, top first) 2/4pt roll down (K5)
- 13.12 Hourglass (middle entry, top first) 2/4pt roll down, inverted entry (K5)
- 13.13 Hourglass (middle entry, bottom first) (K4)
- 13.14 Hourglass (middle entry, bottom first), inverted entry (K4)
- 13.15 Hourglass (middle entry, bottom first) half roll up (K4)
- 13.16 Hourglass (middle entry, bottom first) half roll up, inverted entry (K4)
- 13.17 Hourglass (middle entry, bottom first) 2/4pt roll up (K4)
- 13.18 Hourglass (middle entry, bottom first) 2/4pt roll up, inverted entry (K4)
- 13.19 Hourglass (top entry) (K4)
- 13.20 Hourglass (top entry), inverted entry (K4)
- 13.21 Hourglass (top entry) with half rolls down and up (K5)
- 13.22 Hourglass (top entry) with half rolls down and up, inverted entry (K5)
- 13.23 Hourglass (top entry) with 2/4pt rolls down and up (K5)
- 13.24 Hourglass (top entry) with 2/4pt rolls down and up, inverted entry (K5)
- 14.1 Vertical eight (from bottom) (K3)
- 14.2 Vertical eight (from bottom) inverted entry (K3)
- 14.3 Vertical eight (from bottom) with half rolls (K4)
- 14.4 Vertical eight (from bottom) with half rolls, inverted entry (K4)
- 14.5 Vertical eight (from bottom) with half roll after first half loop (K4)
- 14.6 Vertical eight (from bottom) with half roll after first half loop, inverted entry (K4)
- 14.7 Vertical eight (from middle) (K3)
- 14.8 Vertical eight (from middle) inverted entry (K3)
- 14.9 Vertical eight (from middle) with half roll (K3)
- 14.10 Vertical eight (from middle) with half roll, inverted entry (K3)
- 14.11 Vertical eight (from top) (K3)
- 14.12 Vertical eight (from top) inverted entry (K3)

cont/...

- 14.13 Vertical eight (from top) with half rolls (K4)
- 14.14 Vertical eight (from top) with half rolls, inverted entry (K4)
- 14.15 Vertical eight (from top) with half roll after first half loop (K4)
- 14.16 Vertical eight (from top) with half roll after first half loop, inverted entry (K4)
- 15.1 Square horizontal eight (K5)
- 15.2 Square horizontal eight, inverted entry (K5)
- 15.3 Square horizontal eight (from top) (K5)
- 15.4 Square horizontal eight (from top) inverted entry (K5)
- 15.5 Square vertical eight (from bottom) (K5)
- 15.6 Square vertical eight (from bottom) inverted entry (K5)
- 15.7 Square vertical eight (from bottom) with half rolls (K5)
- 15.8 Square vertical eight (from bottom) with half rolls, inverted entry (K5)
- 15.9 Square vertical eight (from middle) (K5)
- 15.10 Square vertical eight (from middle) inverted entry (K5)
- 15.11 Square vertical eight (from middle) with half roll (K5)
- 15.12 Square vertical eight (from middle) with half roll, inverted entry (K5)
- 15.13 Square vertical eight (from top) (K5)
- 15.14 Square vertical eight (from top) inverted entry (K5)
- 15.15 Square vertical eight (from top) with half rolls (K5)
- 15.16 Square vertical eight (from top) with half rolls, inverted entry (K5)
- 16.1 Figure M with 3/4 rolls (K5)
- 16.2 Figure M with 3/4 rolls, inverted entry (K5)
- 16.3 Figure M with 3/4 pt rolls (K5)
- 16.4 Figure M with 3/4 pt rolls, inverted entry (K5)
- 16.5 Figure M with 3/4pt rolls up, 1/4 rolls down (K5)
- 16.6 Figure M with 3/4pt rolls up, 1/4 rolls down, inverted entry (K5)
Centre half-loop is always flown negative (inverted)
- 17.1 Top hat with 2/4pt rolls (K4)
- 17.2 Top hat with 2/4pt rolls, inverted entry (K4)
- 17.3 Top hat with 2/2pt rolls (K4)
- 17.4 Top hat with 2/2pt rolls, inverted entry (K4)
- 17.5 Top hat from top with 2/4pt rolls (K4)
- 17.6 Top hat from top with 2/4pt rolls, inverted entry (K4)
- 17.7 Top hat from top with 2/2pt rolls (K4)
- 17.8 Top hat from top with 2/2pt rolls, inverted entry (K4)
- 18.1 Humpty bump, half roll up, 2/4pt roll down (K4)
- 18.2 Humpty bump, 1/2 roll up, 2/4pt roll down, inverted entry (K4)
- 18.3 Humpty bump, 2/4pt roll up, full snap down (K5)
- 18.4 Humpty bump, 2/4pt roll up, full snap down, inverted entry (K5)
- 18.5 Humpty bump from top, half roll down, 2/4pt roll up (K4)
- 18.6 Humpty bump from top, half roll down, 2/4pt roll up, inverted entry (K4)
- 18.7 Humpty bump from top, 2/4pt roll down, full roll up (K4)
- 18.8 Humpty bump from top, 2/4pt roll down, full roll up, inverted entry (K4)
- 19.1 2½ turn spin, inverted exit (K3)
- 19.2 2½ turn spin, inverted entry, upright exit (K3)
- 19.3 2 turn opposite spin (K4)
- 19.4 Two turn opposite spin, inverted entry (K4)
- 19.5 Three turn spin (K3)
- 19.6 Three turn spin, inverted entry (K3)
- 19.7 2½ turn spin, half roll exit (K3)
- 19.8 2½ turn spin, half roll exit, inverted entry (K3)
- 20.1 Stall turn 3/4 roll up, 3/4pt roll down (K3)
- 20.2 Stall turn, 3/4 roll up, 3/4pt roll down, inverted entry (K3)
- 20.3 Stall turn 3/4 roll up, 3/4 pt roll down, inverted exit (K3)
- 20.4 Stall turn, 3/4 roll up, 1¼ snap roll down (K5)
- 20.5 Stall turn, 3/4 roll up, 1¼ snap roll down, inverted entry (K5)
- 20.6 Stall turn, 3/4 roll up, 1¼ snap roll down, inverted exit (K5)
- 20.7 Stall turn, 3/4pt roll up, 1¼ snap roll down (K5)
- 20.8 Stall turn, 3/4pt roll up, 1¼ snap roll down, inverted entry (K5)
- 20.9 Stall turn, 3/4pt roll up, 1¼ snap roll down, inverted exit (K5)
- 21.1 Double Immelmann with half rolls (K3)
- 21.2 Double Immelmann with half rolls, inverted entry (K3)
- 21.3 Double Immelmann with half roll first, full roll second (K4)
- 21.4 Double Immelmann with half roll first, full roll second, inverted entry (K4)

cont/...

- 21.5 Double Immelmann with full rolls (K3)
- 21.6 Double Immelmann with full rolls, inverted entry (K3)
- 21.7 Double Immelmann from top, half rolls (K3)
- 21.8 Double Immelmann from top, half rolls, inverted entry (K3)
- 21.9 Double Immelmann from top, half roll first, full roll second (K4)
- 21.10 Double Immelmann from top, half roll first, full roll second, inverted entry (K4)
- 21.11 Double Immelmann from top with full rolls (K4)
- 21.12 Double Immelmann from top with full rolls, inverted entry (K4)
- 22.1 Rolling circle with one roll inside (K5)
- 22.2 Rolling circle with one roll inside, inverted entry (K5)
- 22.3 Rolling circle with one roll outside (K5)
- 22.4 Rolling circle with one roll outside, inverted entry (K5)
- 22.5 Rolling circle with 2 rolls inside (K5)
- 22.6 Rolling circle with 2 rolls inside, inverted entry (K5)
- 22.7 Rolling circle with 2 rolls outside (K5)
- 22.8 Rolling circle with 2 rolls outside, inverted entry (K5)
- 22.9 Rolling circle with 4 rolls inside (K5)
- 22.10 Rolling circle with 4 rolls inside, inverted entry (K5)
- 22.11 Rolling circle with 4 rolls outside (K5)
- 22.12 Rolling circle with 4 rolls outside, inverted entry (K5)

(More than one manoeuvre from the following group is allowed, but not two of the same manoeuvre with only the entry changed)

- 23.1 1½ rolls reversed (K4)
- 23.2 1½ rolls reversed, inverted entry (K4)
- 23.3 Two rolls reversed (K4)
- 23.4 Two rolls reversed, inverted entry (K4)
- 23.5 Four point roll (K4)
- 23.6 Four point roll, inverted entry (K4)
- 23.7 Eight point roll (K4)
- 23.8 Eight point roll, inverted entry (K4)
- 23.9 Two 3/4 pt. rolls reversed (K4)
- 23.10 Two 3/4 pt. rolls reversed, inverted entry (K4)
- 23.11 Two 2/2 pt. rolls reversed (K4)
- 23.12 Two 2/2 pt. rolls reversed, inverted entry (K4)
- 23.13 Two 2/4 pt. rolls reversed (K4)
- 23.14 Two 2/4 pt. rolls reversed, inverted entry (K4)
- 23.15 Slow roll (K3)
- 23.16 Slow roll, inverted entry (K3)
- 23.17 Knife edge flight (K4)
- 23.18 Knife edge flight, inverted entry (K4)
- 23.19 Reverse knife edge flight (K5)
- 23.20 Reverse knife edge flight, inverted entry (K5)
- 23.21 One horizontal snap roll (K3)
- 23.22 One horizontal snap roll, inverted entry (K4)
- 23.23 Two snap rolls reversed (K5)
- 23.24 Two snap rolls reversed, inverted entry (K5)
- 23.25 2/2pt roll, full snap roll opposite (K5)
- 23.26 2/2pt roll, full snap opposite, inverted entry (K5)
- 23.27 2/4pt roll, 1½ snap roll opposite (K5)
- 23.28 2/4pt roll, 1½ snap roll opposite, inverted entry (K5)

5G.8.2. Turnaround manoeuvres

(maximum of two manoeuvres from each group per schedule)

- A.1 Half square loop (K1)
- A.2 Half square loop, inverted entry (K1)
- A.3 Half square loop with half roll up (K2)
- A.4 Half square loop with half roll up, inverted entry (K2)
- A.5 Half square loop with 2/4pt roll up (K2)
- A.6 Half square loop with 2/4pt roll up, inverted entry (K2)
- A.7 Half square loop with 2/2pt roll up (K2)
- A.8 Half square loop with 2/2pt roll up, inverted entry (K2)
- A.9 Half square loop with full roll up (K2)

cont/...

- A.10 Half square loop with full roll up, inverted entry (K2)
- A.11 Half square loop from top (K1)
- A.12 Half square loop from top, inverted entry (K1)
- A.13 Half square loop from top, half roll down (K2)
- A.14 Half square loop from top, half roll down, inverted entry (K2)
- A.15 Half square loop from top, 2/4pt roll down (K2)
- A.16 Half square loop from top, 2/4pt roll down , inverted entry (K2)
- A.17 Half square loop from top, 2/2pt roll down (K2)
- A.18 Half square loop from top, 2/2pt roll down, inverted entry (K2)
- A.19 Half square loop from top, full roll down (K2)
- A.20 Half square loop from top, full roll down, inverted entry (K2)
- A.21 Half square loop from top, full snap down (K3)
- A.22 Half square loop from top, full snap down, inverted entry (K3)
- B.1 Half loop (K1)
- B.2 Half outside loop, inverted entry (K1)
- B.3 Half outside loop from top (K1)
- B.4 Half loop from top, inverted entry (K1)
- C.1 Split "S" (half roll, half loop from top) (K2)
- C.2 Half inside loop, half roll, from top, inverted entry (K2)
- C.3 Half outside loop, full roll, from top (K2)
- C.4 Half inside loop, full roll, from top, inverted entry (K2)
- D.1 Immelmann turn (K2)
- D.2 Immelmann turn, inverted entry (K2)
- D.3 Immelmann turn, full roll (K2)
- D.4 Immelmann turn, full roll, inverted entry (K2)
- E.1 Figure 9 from bottom (K1)
- E.2 Figure 9 from bottom, inverted entry (K1)
- E.3 Figure 9 from bottom, half roll up (K2)
- E.4 Figure 9 from bottom, half roll up, inverted entry (K2)
- E.5 Figure 9 from bottom, 2/4pt roll up (K2)
- E.6 Figure 9 from bottom, 2/4pt roll up, inverted entry (K2)
- E.7 Figure 9 from bottom, 2/2pt roll up (K2)
- E.8 Figure 9 from bottom, 2/2pt roll up, inverted entry (K2)
- E.9 Figure 9 from bottom, full roll up (K2)
- E.10 Figure 9 from bottom, full roll up, inverted entry (K2)
- E.11 Figure 6 from middle (bottom first) (K1)
- E.12 Figure 6 from middle (bottom first), inverted entry (K1)
- E.13 Figure 6 from middle (bottom first), half roll up (K2)
- E.14 Figure 6 from middle (bottom first), half roll up, inverted entry (K2)
- E.15 Figure 6 from middle (bottom first), 2/4pt roll up (K2)
- E.16 Figure 6 from middle (bottom first), 2/4pt roll up, inverted entry (K2)
- E.17 Figure 6 from middle (bottom first), 2/2pt roll up (K2)
- E.18 Figure 6 from middle (bottom first), 2/2pt roll up, inverted entry (K2)
- E.19 Figure 6 from middle (bottom first), full roll up (K2)
- E.20 Figure 6 from middle (bottom first), full roll up, inverted entry (K2)
- E.21 Figure 9 from middle (top first) (K1)
- E.22 Figure 9 from middle (top first), inverted entry (K1)
- E.23 Figure 9 from middle (top first), half roll down (K2)
- E.24 Figure 9 from middle (top first), half roll down, inverted entry (K2)
- E.25 Figure 9 from middle (top first), 2/4pt roll down (K2)
- E.26 Figure 9 from middle (top first), 2/4pt roll down, inverted entry (K2)
- E.27 Figure 9 from middle (top first), 2/2pt roll down (K2)
- E.28 Figure 9 from middle (top first), 2/2pt roll down, inverted entry (K2)
- E.29 Figure 9 from middle (top first), full roll down (K2)
- E.30 Figure 9 from middle (top first), full roll down, inverted entry (K2)
- E.31 Figure 9 from middle (top first), full snap down (K3)
- E.32 Figure 9 from middle (top first), full snap down, inverted entry (K3)
- E.33 Figure 6 from top (K1)
- E.34 Figure 6 from top, inverted entry (K1)
- E.35 Figure 6 from top, half roll down (K2)
- E.36 Figure 6 from top, half roll down, inverted entry (K2)
- E.37 Figure 6 from top, 2/4pt roll down (K2)
- E.38 Figure 6 from top, 2/4pt roll down, inverted entry (K2)
- E.39 Figure 6 from top, 2/2pt roll down (K2)

cont/...

- E.40 Figure 6 from top, 2/2pt roll down, inverted entry (K2)
- E.41 Figure 6 from top, full roll down (K2)
- E.42 Figure 6 from top , full roll down, inverted entry (K2)
- E.43 Figure 6 from top, full snap down (K3)
- E.44 Figure 6 from top, full snap down, inverted entry (K3)
- F.1 Half cuban eight (K2)
- F.2 Half cuban eight, inverted entry (K2)
- F.3 Half cuban eight, 2/4pt roll (K2)
- F.4 Half cuban eight, 2/4pt roll, inverted entry (K2)
- F.5 Half cuban eight, 2/2pt roll (K2)
- F.6 Half cuban eight, 2/2pt roll, inverted entry (K2)
- F.7 Half cuban eight with full roll (K2)
- F.8 Half cuban eight with full roll, inverted entry (K2)
- F.9 Half cuban eight with full snap roll (K3)
- F.10 Half cuban eight with full snap roll, inverted entry (K3)
- F.11 Half cuban eight with 1½ snap roll (K3)
- F.12 Half cuban eight with 1½ snap roll, inverted entry (K3)
- F.13 Half cuban eight from top (K2)
- F.14 Half cuban eight from top, inverted entry (K2)
- F.15 Half cuban eight from top, 2/4pt roll up (K2)
- F.16 Half cuban eight from top, 2/4pt roll up, inverted entry (K2)
- F.17 Half cuban eight from top, 2/2pt roll up (K2)
- F.18 Half cuban eight from top, 2/2pt roll up, inverted entry (K2)
- F.19 Half cuban eight from top, full roll up (K2)
- F.20 Half cuban eight from top, full roll up, inverted entry (K2)
- F.21 Half reverse cuban eight (K2)
- F.22 Half reverse cuban eight, inverted entry (K2)
- F.23 Half reverse cuban eight, 2/4pt roll (K2)
- F.24 Half reverse cuban eight, 2/4pt roll, inverted entry (K2)
- F.25 Half reverse cuban eight, 2/2pt roll (K2)
- F.26 Half reverse cuban eight, 2/2pt roll, inverted entry (K2)
- F.27 Half reverse cuban eight with full roll (K2)
- F.28 Half reverse cuban eight with full roll, inverted entry (K2)
- F.29 Half reverse cuban eight with full snap roll (K3)
- F.30 Half reverse cuban eight with full snap roll, inverted entry (K3)
- F.31 Half reverse cuban eight with 1½ snap roll (K3)
- F.32 Half reverse cuban eight with 1½ snap roll, inverted entry (K3)
- F.33 Half reverse cuban eight from top (K2)
- F.34 Half reverse cuban eight from top, inverted entry (K2)
- F.35 Half reverse cuban eight from top, 2/4pt roll down (K2)
- F.36 Half reverse cuban eight from top, 2/4pt roll down, inverted entry (K2)
- F.37 Half reverse cuban eight from top, 2/2pt roll down (K2)
- F.38 Half reverse cuban eight from top, 2/2pt roll down, inverted entry (K2)
- F.39 Half reverse cuban eight from top, full roll down (K2)
- F.40 Half reverse cuban eight from top, full roll down, inverted entry (K2)
- G.1 Two turn spin (K2)
- G.2 Two turn spin, inverted entry (K2)
- G.3 2 1/2 turn spin (K2)
- G.4 2 1/2 turn spin, inverted entry (K2)
- H.1 Stall turn, half rolls (K2)
- H.2 Stall turn, half rolls, inverted entry (K2)
- H.3 Stall turn, half roll up, 2/4pt roll down (K2)
- H.4 Stall turn, half roll up, 2/4pt roll down, inverted entry (K2)
- H.5 Stall turn, full roll up, half roll down (K2)
- H.6 Stall turn, full roll up, half roll down ,inverted entry (K2)
- H.7 Stall turn, 2/4pt roll up, half roll down (K2)
- H.8 Stall turn, 2/4pt roll up, half roll down, inverted entry (K2)
- H.9 Stall turn, 2/2pt roll up, 2/4pt roll down (K2)
- H.10 Stall turn, 2/2pt roll up, 2/4pt roll down, inverted entry (K2)
- H.11 Stall turn, half roll up, full snap down (K4)
- H.12 Stall turn, half roll up, full snap down, inverted entry (K4)
- H.13 Stall turn, 3/4pt roll up, 1/4 roll down (K3)
- H.14 Stall turn, 3/4pt roll up 1/4 roll down, inverted entry (K3)
- H.15 Stall turn, 3/4 roll up, 1¼ snap down (K4)

cont/...

- H.16 Stall turn 3/4 roll up, 1¼ snap down, inverted entry (K4)
- J.1 Top hat, 3/4 roll up, 1/4 roll down (K2)
- J.2 Top hat, 3/4 roll up, 1/4 roll down, inverted entry (K2)
- J.3 Top hat, 3/4pt roll up, 3/4 roll down (K2)
- J.4 Top hat, 3/4pt roll up, 3/4 roll down, inverted entry (K2)
- J.5 Top hat, 3/4pt roll up, 3/4 pt roll down, inverted exit (K2)
- J.6 Top hat, 3/4pt roll up, 3/4pt roll down, inverted entry and exit (K2)
- J.7 Top hat, 1/4 roll up, 1/4 roll down (K2)
- J.8 Top hat, 1/4 roll up, 1/4 roll down, inverted entry (K2)
- J.9 Top hat, 1/4 roll up, 1/4 roll down, inverted exit (K2)
- J.10 Top hat, 1/4 roll up, 1/4 roll down, inverted entry and exit (K2)
- J.11 Top hat from top, 3/4 roll down, 3/4pt roll up (K3)
- J.12 Top hat from top, 3/4 roll down, 3/4pt roll up, inverted entry (K3)
- J.13 Top hat from top, 3/4 roll down, 1/4 roll up (K2)
- J.14 Top hat from top, 3/4 roll down, 1/4 roll up, inverted entry (K2)
- J.15 Top hat from top, 1/4 roll down, 3/4pt roll up (K2)
- J.16 Top hat from top, 1/4 roll down, 3/4pt roll up, inverted entry (K2)1¼
Horizontal (cross-box) flight is always flown inverted.
- K.1 45 degree up, 2/4pt roll, half loop (inside or outside), full roll down (K3)
- K.2 45 degree up, 2/4pt roll, half loop (inside or outside), full roll down, inverted entry (K3)
- K.3 45 degree up, 2/2pt roll, half loop (inside or outside), 2/4pt roll down (K3)
- K.4 45 degree up, 2/2pt roll, half loop (inside or outside), 2/4pt roll down, inverted entry (K3)
- K.5 45 degree up, full roll, half loop (inside or outside), 2/4pt roll down (K3)
- K.6 45 degree up, full roll, half loop (inside or outside), 2/4pt roll down, inverted entry (K3)
- K.7 45 degree up, 2/2pt roll, half loop (inside or outside), full snap roll down (K4)
- K.8 45 degree up, 2/2pt roll, half loop (inside or outside), full snap roll down, inverted entry (K4)
- L.1 Humpty bump (pull, pull, push) half roll up, 2/4pt roll down (K3)
- L.2 Humpty bump (push, push, pull) half roll up, 2/4pt roll down, inverted entry (K3)
- L.3 Humpty bump (pull, pull, pull) half roll up, 2/2pt roll down (K3)
- L.4 Humpty bump (push, push, push) half roll up, 2/2pt roll down, inverted entry (K3)
- L.5 Humpty bump (pull, pull, push) 2/4pt roll up, half roll down (K3)
- L.6 Humpty bump (push, push, pull) 2/4pt roll up, half roll down, inverted entry (K3)
- L.7 Humpty bump (pull, pull, push, or pull, push, push) 1/4 roll up, 3/4 roll down (K3)
- L.8 Humpty bump (push, pull, pull, or push, push, pull) 1/4 roll up, 3/4 roll down, inverted entry (K3)
- L.9 Humpty bump (pull, pull, pull) 3/4pt roll up, 1/4 roll down (K3)
- L.10 Humpty bump (push, pull, pull) 3/4pt roll up, 1/4 roll down, inverted entry (K3)
- L.11 Humpty bump with roll options, (half roll up or 1/4 roll up and down) (K2)
- L.12 Humpty bump with roll options, (half roll up or 1/4 roll up and down) inverted entry (K2)
- M.1 Humpty bump from top, half roll down (push, push, push) (K3)
- M.2 Humpty bump from top, half roll down, inverted entry (pull, pull, pull) (K2)
- M.3 Humpty bump from top, 2/4pt roll down, half roll up (push, push, pull) (K3)
- M.4 Humpty bump from top, 2/4pt roll down, half roll up, inverted entry (pull, pull, push) (K3)
- M.5 Humpty bump from top, 2/4pt roll down, 2/2pt roll up (push, push, push) (K3)
- M.6 Humpty bump from top, 2/4pt roll down, 2/2pt roll up, inverted entry (pull, pull, pull) (K3)
- M.7 Humpty bump from top, 1/4 roll down, 3/4 roll up (push, push, push) (K3)
- M.8 Humpty bump from top, 1/4 roll down, 3/4 roll up, inverted entry (pull, push, push) (K3)
- M.9 Humpty bump from top, 1/4 roll down, 3/4 roll up, inverted entry and exit (pull, push, pull) (K3)
- M.10 Humpty bump from top, 1/4 roll down, 3/4 roll up, inverted exit (push, push, pull) (K3)

5.10. CLASS F3M – LARGE RADIO CONTROLLED AEROBATIC POWER MODEL AIRCRAFT

5.10.1. Definition of a Large Radio Controlled Aerobatic Power Model Aircraft

Model aircraft, but not a helicopter, which is aerodynamically manoeuvred by control surface(s) in attitude, direction, and altitude by a pilot on the ground using radio control.

The model aircraft must be a scaled-down version of a full-size aircraft that is able to perform aerobatics. The competitor must prove this by providing a dossier to the contest director, including a minimum of a three-view drawing and a photograph of the full-size aircraft.

5.10.2. Definition of a competition for model aircraft class F3M

A competition for model aircraft class F3M is based on three tasks:

- One task of a known schedule, valid for two years.
- One task of an unknown schedule. This unknown schedule is given to each pilot before the task, without any possibility of practising the schedule. The difficulty of this task will be equivalent to that of the known schedule.
- A freestyle schedule of the competitor's choice.

5.10.3. General Characteristics of a large R/C Aerobatic Power Model Aircraft

Minimum overall span for monoplanes	2.1 m
Minimum overall span for biplanes.....	1.8 m
Maximum flying weight without fuel.....	20 kg

Paragraph B.3.1.a) of Section 4B (Builder of Model Aircraft) is not applicable to class F3M.

For Power device limitations, Noise rule, and Radio Equipment: See 5.1.2

The maximum noise level will be 94 dB(A) measured at 7 m from the centre line of the model aircraft with the model aircraft placed on the ground over concrete or macadam at the flying site. With the motor running at full power measurement will be taken 90 degrees to the flight path on the right hand side and downwind from the model aircraft. The microphone will be placed on a stand 30 cm above the ground in line with the motor. No noise reflecting objects shall be nearer than 7 m to the model aircraft or microphone. The noise measurement will be made prior to each flight. If a concrete or macadam surface is not available then the measurement may be taken over bare earth or very short grass in which case the maximum noise level will be 92 dB(A). In the event a model aircraft fails the noise test, no indication shall be given to the pilot, and/or his team, or the judges and both the transmitter and the model aircraft shall be impounded by the flight line official immediately following the flight. No modification or adjustment to the model aircraft shall be permitted (other than refuelling). The model aircraft shall be retested by a second noise steward using a second noise meter and in the event that the model aircraft fails the retest, the score for the preceding flight shall be zero.

The flight time will be interrupted while the noise check at the flying site is being made. The competitor shall not be delayed more than 30 seconds for the noise check.

To be eligible to compete, the competitor or his helper/team manager must submit the following documentation, before the start of the competition:

- a) An accurate three-view drawing of the subject aircraft (home made drawings by the competitor or other draftsman are not acceptable).
- b) The dimensions are considered on the top view and side view of the subject aircraft.
- c) The scale of the model aircraft is calculated from the wing span.
- d) Dimensions described on the drawing overleaf can be measured. A tolerance is allowed as follows:
D is the full size measure in cm, s is scale, d is model measure in cm:
 $(D \times s) \times 0.9 - 0.5 \leq d \leq (D \times s) \times 1.1 + 0.5$

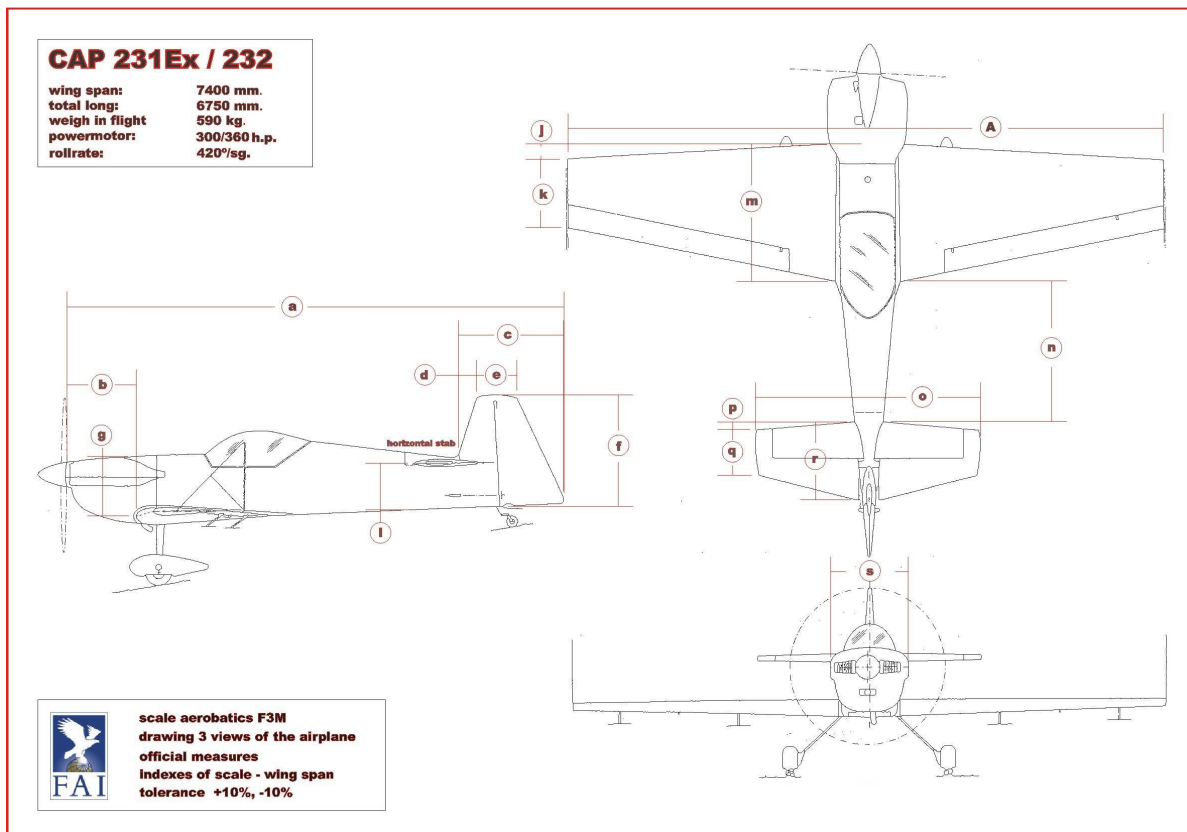

- e) The area of control surfaces compared to fixed surfaces will not be considered. Example: only the outline of the wing, stabiliser and fin will be considered, not the ailerons, elevator, or rudder, but the concept of moving surfaces must be the same as on the subject aircraft. (Aileron perhaps in two parts, moving part of the fin for aerodynamic balance, etc. Trim tabs are forbidden, if not on the full-size aircraft.)
- f) The competitor must be able to provide any technical data for technical checking. If the dimensions are not in accordance with the rules, the model aircraft is not allowed to fly and the competitor is disqualified.

5.10.4. **Definition and number of helpers:** see 5.1.3

5.10.5. **Number of flights:** Each competitor has the right to a minimum of three official flights (one known schedule + one unknown schedule + one freestyle schedule).

5.10.6. **Definition of an attempt:** see 5.1.5.

5.10.7. **Number of attempts:** see 5.1.6.

5.10.8. **Definition of an official flight:** see 5.1.7.

5.10.9. **Marking:**

Each manoeuvre may be awarded marks, in whole number increments, between 10 and 0 by each of the judges during the flight. These marks are multiplied by a coefficient that varies with the difficulty of the manoeuvre. Any manoeuvre not completed shall be scored zero (0). Manoeuvres must be performed where they can be seen clearly by the judges. If a judge, for some reason outside the control of the competitor, is not able to follow the model aircraft through the entire manoeuvre, he may set the «Not Observed» (N.O.) mark. In this case, the judge's mark for that particular manoeuvre will be the average of the numerical marks given by the other judges. Centre manoeuvres should be performed in the centre of the manoeuvring area while turn around manoeuvres should not extend past a line 70 degrees left and right of centre. Vertical height should not exceed 70 degrees. Also, manoeuvres should be performed along a line of approximately 150m in front of the competitor. Infractions to this rule will be cause for downgrading by each judge individually and in proportion to the degree of infraction. The manoeuvring area will be clearly marked with white vertical poles, a minimum of 100mm in diameter and a minimum of 4m high, placed on centre, and at 70 degrees each side of centre on a line 150m in front of the competitor. Flags and/or streamers of contrasting colour should be mounted on the poles to improve visibility. White (or contrasting) lines originating at the competitor's position and extending outward at

least 50m will also be used to mark the centre and extreme limits (70 degrees left and right of centre) of the manoeuvring zone. Audible and visual signals to indicate violations of the manoeuvring zone are not to be employed.

The judges shall be seated no more than 10m, and not less than 7m behind the competitor's position (the apex of the 70 degree lines) and within an area described by the extension of the 70 degree lines to the rear of the competitor.

At the conclusion of the flight, each judge will independently consider if the in-flight sound level of the model aircraft is too loud. If a majority of the judges consider the model aircraft too loud, the flight score will be penalised 10 points for each counting judge.

If a model aircraft is in the opinion of the safety steward or the judges, unsafe or being flown in an unsafe manner, they may instruct the competitor to land the model aircraft.

The scores given by each judge for each competitor shall be made public at the end of each round of competition.

5.10.10. Classification:

Classification will be done considering the sum of the three scores: known, unknown, and freestyle.

In the case where two flights of each schedule have been completed, the sum of the best known, the best unknown, and the best free-style scores will be considered.

In the case where three flights have been completed, only the best score of the repeated flight (known, unknown, and free-style) will be added to the single other flight score.

Example: one known, two unknowns, and a free-style have been completed: Classification is done by adding the known score and the free-style score to the best score of the two unknown flights.

The final classification is done by the sum of the three considered flight scores in each category, multiplied by the following coefficients:

- Known35%
- Unknown45%
- Freestyle.....20%

1000 points will be awarded to the competitor obtaining the highest total for his three retained flight scores. The scores are then normalised to 1000 points as described below:

$$\text{Points}_x = \frac{S_x}{S_w} \times 1000$$

Points_x = Points given to competitor x

S_x = Score of Competitor x

S_w = Score of Winner

The TBL statistical averaging system is not to be applied for the moment. However, as soon as possible, the organisers of competitions for this class may start to use scoring software using the TBL algorithm.

5.10.11. Judging:

The criteria to be applied for judging the manoeuvres in this class, are identical to class F3A. However, the judges will have to consider the dimensions and inertia of the model aircraft. The manoeuvres must be flown slower than with F3A model aircraft, but should be more realistic.

The organiser must appoint a panel of five judges. For each manoeuvre, only three scores are counted, the lowest and the highest scores being discarded.

cont/...

5.10.12. **Organisation for Large R/C Aerobatic Model Aircraft Contests**

For transmitters and frequency control, see section 4B, paragraph B.11.

The draw for flight order will be done for the first task (known, unknown, or freestyle). For the subsequent tasks, the flight order will start at 1/6, 1/3, 1/2, 2/3 and 5/6 down the list.

During the flight, the competitor must stay in front of the judges in the designated area and under the supervision of the Flight Line Director and safety steward.

Competitors must be called at least five minutes before they are required to occupy the starting area.

If his frequency is clear, the competitor will be given his transmitter when he occupies the starting area so that he can perform a radio check. Utmost care must be taken by the competitor in the starting area, to not disturb the concentration of the competitor who may be flying.

If there is a frequency conflict the competitor must be allowed a maximum of one minute for a radio check before the start of the 3-minute starting time. The timer will notify the competitor when the minute is finished, and immediately start the 3-minute starting time.

5.10.13. **Execution of manoeuvres**

The manoeuvres must be executed during an uninterrupted flight in the order in which they are listed on the score sheet. The competitor may make only one attempt at each manoeuvre during the flight. The pilot has three minutes to start his motor, and eleven minutes to complete his flight; both the three minutes and the eleven minutes to start when the competitor is given permission to start his motor.

The model aircraft must take-off and land unassisted, that is, no hand launched flights. If any part of the model aircraft is dropped during the flight, scoring will cease at that point and the competitor must be instructed to land his model aircraft immediately.

The direction of the manoeuvres is determined by the heading of the model aircraft during the take-off.

The flight ends when the landing sequence is completed.

Scoring will cease with the expiry of the eleven-minute flight period.

After the known flying schedule has been completed, the competitor is not allowed a free pass, and the landing must follow immediately. Any free passes will result in a zero score for the landing.

The model aircraft must land in the landing area, defined by a 50 metres diameter circle, or within two lines marked on the runway and separated by 100 metres if the runway is wider than 10 metres.

The landing point is considered as the first point where the model aircraft touches the ground. Landing out of the landing area, or a crash will result in a zero score for the landing.

The landing sequence is completed when the model aircraft has run for 10m or comes to a stop within 10 metres.

5.10.14. **Schedules of manoeuvres.**

- a) The **known schedule** is valid for a two-year period.
- b) The **unknown schedule** is given to the competitors in the evening preceding the competition day, or on the morning of the competition day, with no possibility of practice flying. In a proven case of a competitor having practised the unknown schedule, the competitor must be disqualified.

This schedule must be completely new, unknown, and equal in difficulty factor to the known schedule.

For each manoeuvre, judges and competitors must refer to the F3A rules that define all manoeuvres, and errors to be avoided. The same basic criteria of judging are to be used for dimensions of manoeuvres and judging of longitudinal distance (but 70° on each side, and about 150m in distance).

cont/...

Before the beginning of the task of the unknown schedule, the judging co-ordinator will brief the judges and the competitors to clearly explain the manoeuvres, and what is expected from the competitors.

Knowledge of the Aresti cryptographic system is highly recommended to all competitors and judges.

Known and unknown schedules must use patterns according to the full size FAI Aresti catalogue.

c - Freestyle schedule:

Freestyle schedules give a competitor the opportunity to demonstrate his own skill and the qualities of his model aircraft. There are no rules governing the composition of the schedules. However, safety is of prime importance.

The model aircraft flown by a competitor in the freestyle task may be different from the one flown for the two other schedules, provided this model aircraft conforms to the general characteristics of the F3M class.

The maximum duration of a freestyle flight is five (5) minutes, from the take-off signal, to the landing. The competitor will be notified at one minute before the end of the five-minute period.

After the end of the five-minute period, the judges cease to consider any further manoeuvres that may have been performed. If the model aircraft is still airborne, it must be landed immediately, otherwise the judges will mark a zero score for the criteria "Technicality of the manoeuvres" (K2).

Known schedule of manoeuvres	K-Factor
01 - Take-off sequence	1
02 - Inside loop, upper half in knife edge flight, full snap roll (positive or negative) on top	4
03 - Humpty bump (+++) with stall turn, ¼ roll up, ¼ roll down, then stall turn with ½ roll up and down	3
04 - Alternating knife edge flight, exit inverted	4
05 - Half cuban eight with 2-point roll, entry inverted	2
06 - Triangle loop with rolls in up and down lines and with two opposite negative snap rolls in upper line	3
07 - Humpty bump (+ - +) with full roll up and two snap rolls (+ or -) down, exit inverted	2
08 - Three opposite rolls in circle (each 120 degree), first roll outside, entry & exit inverted	4
09 - Half diamond loop, with full rolls in both sides, entry inverted	2
10 - Double reversed hat with half rolls in all verticals, and snap rolls in horizontal lines (2 x negative, 1 x positive)	5
11 - Two and half revolutions of normal spin	2
12 - Alternating 4-point roll (3 x ¼ roll and 3 x ¼ roll in opposite direction)	4
13 - ¾ of vertical eight, with integrated full roll in bottom half loop, and positive snap roll on the top of the upper loop	3
14 - Landing sequence	1
	40

The description of the manoeuvres, including judging notes, and the Aresti diagrams are given at Annex 5L

cont/...

5.10.15. **Marking criteria – Freestyle**

Judging of the Freestyle task comprises five elements. Each element contains several criteria, with marks ranging from 10 to 0. Each mark is multiplied by a difficulty coefficient (K-Factor).

Originality: Three criteria:

New Manoeuvres: K= 2

The use of completely new manoeuvres, or manoeuvres not often used, or a diverse range of manoeuvres.

Enhancers. Smoke producing devices, or streamers. K=1.

The use of these devices should be used only to accentuate or emphasise some manoeuvres. Improper or inefficient use, even if impressive, should not result in full marks being given.

Harmony with music: K= 3

If there is musical accompaniment, the flying and the manoeuvres should be in complete harmony with the music, and the music must not be used only as background.

Harmony and Rhythm: Two criteria

Setting of the manoeuvres: K= 2

The schedule must be well structured, with good placement and positioning of the manoeuvres, giving judges the best visibility of the entire performance. Safety is of prime importance.

Sequence of manoeuvres: K= 2.

The entire flight must retain the interest of judges, with a natural flow from start to finish, with coherent matching of manoeuvres.

Performing of the manoeuvres: Three criteria

Technicality of the manoeuvres: K= 2 .

Complicated and technically challenging manoeuvres must be awarded higher marks, provided there is not a lack of quality in their execution. Simple and less complex manoeuvres should attract fewer marks.

Quality: K= 2.

The entire flight must be devoid of “missed” manoeuvres, and must exhibit all-round good quality. The fact that it is a freestyle schedule must not allow the performance to become sub-standard in technicality and quality. It is not intended to be a circus performance.

Diversity: K= 2

The competitor must avoid repetitive use of the same manoeuvres, and only in exceptional circumstances will repeat manoeuvres be tolerated to emphasise a particular passage in the music.

Safety of the flight:

Safety: The impression must be created with the judges that the competitor is in absolute control of the model aircraft. The safety of persons or equipment should never be endangered during a flying performance.

5.10.16. **Safety**

The contest director will nominate a safety line officer/steward. This officer/steward is in charge of safety and will be located within hearing distance from the competitor. The safety steward must observe the model aircraft and the competitor’s actions during a flight, and is empowered to instruct a competitor to terminate his flight and to land his model aircraft immediately if necessary during a safety conflict.

During the Freestyle schedule, the distance between the manoeuvring area and the competitor must be a minimum of 20m. Any manoeuvre performed at a distance closer than 20m to the competitor will score zero marks.

Near the 20m line, model aircraft should be flown either parallel to the public line, or away from it.

The manoeuvring area frame defined for known and unknown schedules is not imposed on the Freestyle schedule. However, any flying behind the competitor will attract an immediate instruction by the safety steward for the competitor to terminate his flight, and the entire flight will score zero points.

ANNEX 5L

F3M – RADIO CONTROLLED AEROBATIC MODEL AIRCRAFT

DESCRIPTION OF MANOEUVRES – KNOWN SCHEDULE

01- Take-off sequence :

The model aircraft is placed on the runway, takes off, then turns 90 degrees towards the line defined by the upwind and downwind marker. When approximately over this line the model aircraft turns 270 degrees for a downwind trim pass. When approximately even with the downwind marker the model aircraft initiates a 180 degree turn, reversal, or other turn-around figure of the pilot's choice.

Judging Notes:

- Take off sequence not followed, zero points.
- Model aircraft passes behind the judges line (zero line), zero points.
- Only two scores, a zero or a 10, may be awarded for the take-off sequence.

02- Inside loop, upper half in knife edge flight, full snap roll (positive or negative) on top:

Model performs $\frac{1}{4}$ of inside loop, then $\frac{1}{4}$ roll to knife edge in which performs second $\frac{1}{4}$ of the loop, then full snap roll (positive or negative) and third $\frac{1}{4}$ of loop in knife edge position, then $\frac{1}{4}$ roll and last $\frac{1}{4}$ of loop to level flight.

Judging notes:

- •Wing of the model is not in vertical plane during the knife edge flight
- •Model is not keeping round shape of the manoeuvre

03- Humpty bump (+ + +) and stall turn, $\frac{1}{4}$ roll up, $\frac{1}{4}$ roll down then stall turn with $\frac{1}{2}$ roll up and down:

Pull to vertical up line, then $\frac{1}{4}$ roll and $\frac{1}{2}$ of inside loop to vertical down line, then $\frac{1}{4}$ roll and $\frac{1}{2}$ inside loop to vertical up line, $\frac{1}{2}$ roll and then stall turn to vertical down line, $\frac{1}{2}$ roll and pull to level flight.

Judging notes:

- •Humpty bump other than (+ + +) – zero points
- •Stall turn with radius bigger than two wing span – zero points
- •Vertical lines not true vertical

04- Alternating knife edge flight, exit inverted:

Model performs in level flight $\frac{1}{4}$ roll to knife edge flight, hesitates briefly and then performs $\frac{1}{2}$ roll to opposite knife edge flight, hesitates briefly and performs $\frac{1}{4}$ roll to inverted level flight.

Judging notes:

- •Wing is not in vertical plane during knife edge flights
- •The length of knife edge parts has to be the same
- •The $\frac{1}{2}$ roll has to be on the centre line of the flight area

05- Half cuban eight with 2-point roll, entry inverted:

From inverted level flight push to perform $\frac{5}{8}$ of outside loop to 45 degree down line, then 2-point roll and pull to level flight.

Judging notes:

- •The part of outside loop is not round shaped
- •2-point roll is not in the middle of down line

cont/...

06- Triangle loop with rolls in up and down lines and with two opposite negative, snap rolls in upper line:

Pull to 45 degree up line, perform full roll, then pull to horizontal inverted flight and perform two opposite negative snap rolls, then push to down line 45 degree with full roll and pull to level flight.

Judging notes:

- • Both opposite snap rolls have to be in the middle of upper line
- • The full rolls have to be in the middle of 45 degree lines
- • The radii of corner loops have to be the same
- • Up and down lines are not true 45 degrees

07- Humpty bump (+ - +) with full roll up and two snap rolls (negative or positive) down, exit inverted:

From level flight pull to vertical up line, perform full roll, then $\frac{1}{2}$ outside loop to vertical down line and two negative or positive snap rolls and then push to level inverted flight.

Judging notes:

- • Humpty bump other than (+ - +) – zero points
- • The rolls have to be in the middle of the verticals

08- Three opposite rolls in circle (each 120 degree), first roll outside, entry and exit inverted:

Model from inverted level flight performs three integrated opposite rolls in level circle. For each roll there is the segment of 120 degrees.

Judging notes:

- • Model is changing altitude during the circle
- • The roll rate of the rolls is not constant
- • The circle is not round shaped

09- Half diamond loop with full rolls in both sides, entry inverted:

From level inverted flight push to 45 degree up line, then perform full roll and then $\frac{1}{4}$ inside loop to 45 degree up line with second full roll and push to level flight.

Judging notes:

- • The rolls are not in the middle of the diamond sides
- • The up lines are not true 45 degrees

10- Double reversed hat with $\frac{1}{2}$ rolls in all verticals and snap rolls in horizontal lines (2 x negative, 1 x positive):

Model performs two reversed top hats with $\frac{1}{2}$ rolls in the up and down verticals and with negative snap rolls in the bottom horizontal lines and one positive snap roll in the upper horizontal line.

Judging notes:

- • The $\frac{1}{2}$ rolls are not in the middle of the verticals
- • Snap rolls are not in the middle of horizontal lines
- • Both hats have to be the same size

11- Two and half revolutions of normal spin:

From level flight is model slowing down and performs two and half turns of normal spin ending in vertical down line and pull to level flight.

Judging notes:

- • Spin not ending correctly – apply the 15 degree rule for downgrading
- • Forced entry of the spin – downgrade 4 – 5 points
- • Entry via snap roll – zero points

cont/...

12- Alternating 4-point roll (3 x ¼ roll and 3 x ¼ roll in opposite direction):

From level flight model performs 3 points of 4-point roll followed by 3 points of 4-point roll in opposite direction.

Judging notes:

- The roll rate in both directions has to be the same
- The pauses between ¼ rolls have to be the same length

13- ¾ of vertical eight with integrated full roll in bottom ½ loop and positive snap roll on top of upper loop:

Model performs half of inside loop with integrated full roll and then full outside loop with positive snap roll on the top and finally ½ roll on the exit from the manoeuvre.

Judging notes:

- Both loops do not have the same radius
- The upper loop is not correctly above the bottom ½ loop

14- Landing sequence :

At reduced power execute a 180 degree level or descending turn to a downwind heading. Fly a downwind leg, then turn 180 degrees into the wind. Fly a descending approach to the runway touching down in the landing zone. The landing sequence is completed when the model aircraft has either rolled 10 meters or comes to rest.

Judging notes:

- Model aircraft does not follow landing sequence, zero point.
- If any landing gear leg retracts on landing, zero point.
- If the model aircraft lands outside the landing zone, zero point. The landing zone is designated by a circle of 50 meters radius or lines across a standard runway spaced 100 meters apart where the runway is at least 10 meters wide.
- Only two scores, a zero or a ten, may be awarded for the landing sequence.

The Aresti diagrams appear overleaf.



F3M KNOWN SCHEDULE

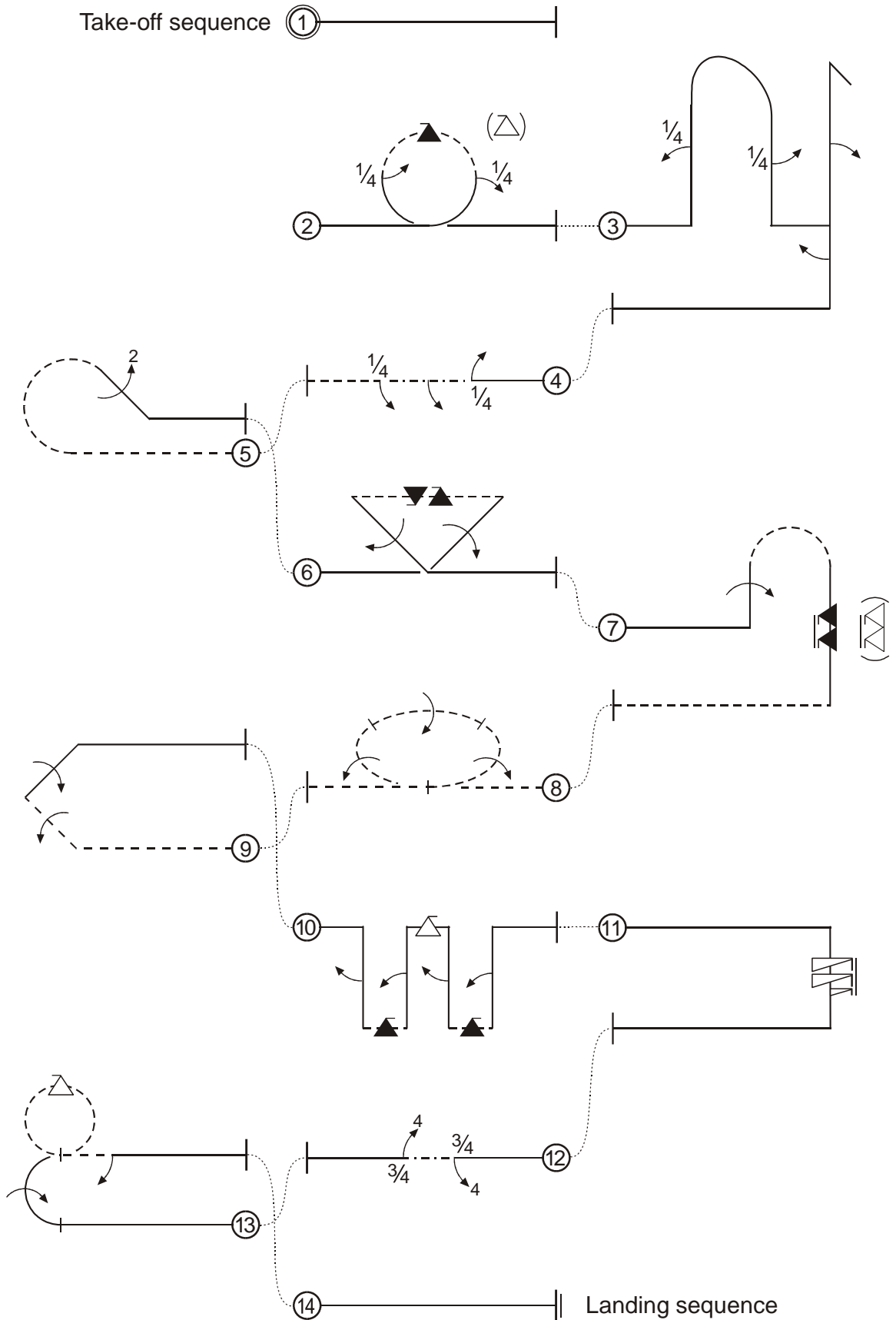
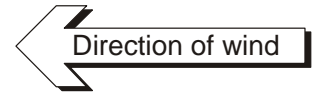

Drawings by Bob Skinner
CorelDraw 9 - January 2009



5.9. CLASS F3P – INDOOR RADIO CONTROL AEROBATIC POWER MODEL AIRCRAFT

5.9.1 Definition of an R/C Indoor Aerobatic Power Model Aircraft

A model aircraft, but not a helicopter, which flies indoors (usually a hall) and is aerodynamically manoeuvred by control surface(s) in attitude, direction, and altitude by a pilot on the ground using radio control.

5.9.2 General Characteristics of R/C Indoor Aerobatic Power Model Aircraft

Maximum total weight.....300g

External parts that protrude which could be considered dangerous, (ie landing gear struts, shaft tips etc) must be covered in order to avoid injuries.

Power device limitations: Any suitable power device may be utilised except those generating any kind of exhaust emission. Electric powered model aircraft are limited to a maximum of 42 Volts for the propulsion circuit.

Paragraph B.3.1.a) of Section 4B (Builder of Model aircraft) is not applicable to class F3P.

Radio equipment shall be of the open loop type (ie no electronic feedback from the model aircraft to the ground). Auto-pilot control utilising inertia, gravity or any type of terrestrial reference is prohibited. Automatic control sequencing (pre-programming) or automatic control timing devices are prohibited.

Example: Permitted:

1. Control rate devices that are manually switched by the pilot.
2. Any type of button or lever control that is initiated and terminated by the pilot
3. Manually operated switches to couple control functions.

Not permitted:

1. Snap buttons with automatic timing mode.
2. Pre-programming devices to automatically perform a series of commands.
3. Auto-pilots for automatic wing levelling.
4. Propeller pitch change with automatic timing mode.
5. Any type of voice recognition system.
6. Any type of learning function involving manoeuvre to manoeuvre or flight to flight analysis.

5.9.3 Definition and Number of Helpers

A helper may be a Team Manager, another competitor or an officially registered supporter. Each pilot is permitted one helper during the flight.

5.9.4 Number of Flights

Competitors have the right to the same number of flights. Only completed rounds will be counted.

5.9.5 Definition of an Attempt

There is an attempt when the competitor is given permission to start.

Note: If the motor fails to start within the one (1) minute allowed, the competitor must immediately make room for the next competitor. If the motor stops after the take-off has begun, but before the model aircraft is airborne, it may be restarted within the one (1) minute starting period.

5.9.6 Number of Attempts

Each competitor is entitled to one (1) attempt for each official flight.

Note: An attempt can be repeated at the contest director's discretion only when for any unforeseen reason outside the control of the competitor the model aircraft fails to start (eg there is radio interference). Similarly, in a flight that is interrupted by any circumstance beyond the control of the competitor, the competitor is entitled to have a reflight, but only manoeuvres affected and the unscored manoeuvres that follow will be judged.

5.9.7 Definition of an Official Flight

There is an official flight when an attempt is made whatever the result.

5.9.8 Marking

Each manoeuvre may be awarded marks, in whole number of increments, between 10 and 0 by each of the judges during the flight. These marks are multiplied by a coefficient that varies with the difficulty of the manoeuvre. Any manoeuvre not completed shall be scored zero (0). Manoeuvres must be performed where they can be seen clearly by the judges. If a judge, for some reason outside the control of the competitor, is not able to follow the model aircraft through the entire manoeuvre, he may set the "Not Observed" (N.O.) mark. In this case, the judge's mark for that particular manoeuvre will be the average of the numerical marks given by the other judges. Centre manoeuvres should be spaced equally above the centre line of the manoeuvring area, with turn around manoeuvres at the left or right of it. Infractions of this rule will be cause for downgrading by each judge individually and in proportion to the degree of infraction.

Aerobatics Freestyle to Music (AFM) are judged for flying style, artistic quality, and overall performance, in marks of whole number increments between 10 and 0 by each of the judges for the overall flight.

Judges shall be seated on a line parallel to the longest wall of the hall and in the middle between its side walls, while viewing the opposite longest wall.

The manoeuvring area is limited by the floor, ceiling, and walls of the hall, as well as by the safety line (the line that the judges are seated on). A model aircraft must never cross this safety line. The centre line of the manoeuvring area stretches from the safety line (perpendicular) to the opposite long wall, and is positioned in the middle between the side walls. The recommended dimensions of the hall should be about 40 x 20 metres in length and width and between 8 to 12 metres in height.

Audible and visual signals to indicate violations of the manoeuvring area are not to be employed.

If a model aircraft is unsafe in the opinion of judges or being flown in an unsafe manner, they may instruct the competitor to land.

The scores given by each judge for each competitor shall be made public at the end of each round of competition.

5.9.9 Classification

Each competitor will have four (4) preliminary flights (schedule F3P-AP), the sum of the best three counting to determine a first individual classification and the team placing if necessary. All preliminary scores will be normalised to 1000 points as described below. The top 20% (twenty percent) of the classified pilots with a minimum of five (5) will have three (3) additional flights. These final flights will be flown as a known, finals schedule (schedule F3P-AF). The total of the best three preliminary flights normalised again to 1000 points will count as one score. This score and the three finals scores will give four (4) normalised scores. The sum of the three best will give the final classification. In the case of a tie, the sum of all the scores will determine the winner.

The scores of all the preliminary rounds and finals will be computed using the Tarasov-Bauer-Long (TBL) statistical averaging scoring system. Only computer tabulation systems containing the TBL algorithm and judge analysis programs and approved by the CIAM Bureau can be used at World and Continental Championships. All scores for each preliminary round and finals will be normalised as follows: when all the competitors have flown in front of a particular group of judges (ie a round) the highest score will be awarded 1000 points. The remaining scores for that group of judges are then normalised to a percentage of the 1000 points in the ratio of actual score over winner's score.

$$\text{Points}_x = \frac{S_x}{S_w} \times 1000$$

Points_x = points awarded to competitor X

S_x = score of competitor X

S_w = score of winner of round

Note 1: Final flights to determine the individual winner are only required for World and Continental Championships. For smaller contests, the total of the three best preliminary flights may be used to determine the individual winner and the team placing.

Note 2: The TBL system can only be applied for events with at least 10 competitors and 5 judges. For those smaller events that are not scored with the TBL system, the high and low scores for each manoeuvre will be discarded if four or more judges are used.

5.9.10 Judging

- a) For each competition in F3P, there must be a minimum of three (3), and a maximum of five (5) judges, plus one timer.
- b) For larger events, there might be several groups of judges.
- c) For World or Continental Championships the organiser must appoint one panel of five judges. The judges must be of different nationalities and must be selected from a current list of international Judges. Those selected must reflect the approximate geographical distribution of teams having participated in the previous World Championships and the final list must be approved by the CIAM Bureau.
- d) The invited judges must have had F3P judging experience within the previous twelve months and must submit a resume of his judging experience to the organiser when accepting the invitation to judge at a World or Continental Championship. The organiser must in turn submit the resumes to the CIAM Bureau along with the judges list for approval.
- e) Before every World or Continental Championship, there shall be a briefing for the judges, following by training flights by non-competitors. Also, warm up flights for the judges should be flown by non-competitors before the first official preliminary flight each day. After the preliminary flights, the highest placing non-finalist should be awarded the honour of performing the warm-up flights for finals schedule. Warm-up flights should be judged but under no circumstances should be tabulated. Any deviations from the above procedures must be stated in advance by the organisers and must have prior approval by the CIAM or the CIAM Bureau.
- f) Each judge has to assess each manoeuvre and any other relevant action of the competitor individually and independently from the other judges. The criteria for judging are contained in the Description of Manoeuvres (Annex 5M) and in the Judge's Guide (Annex 5B).
- g) To avoid errant judging, it is recommended that training flights be performed, before the beginning of official flying. These training flights are judged and tabulated according to the regulations, but the results are not made public.

5.9.11 Organisation for R/C Indoor Aerobatic Contests

- a) For transmitter and frequency control see Section 4B, Para. B.11. The draw for the flight order will be done for each flight line, except when possible, frequency will not follow frequency, nor team member follow team member. Also team members on separate flight lines will be separated by at least two competitors.
- b) For flights two, the flight order will start in the middle of the original flight draw and then from the beginning to the middle. For flights three, the flight order is the same as the original draw, but in reverse.
- c) During the flight, the competitor must stay in proximity of the judges and under the supervision of the Flight Line Director.
- d) Competitors must be called at least five (5) minutes before they are required to occupy the starting area.
- e) If his frequency is clear the competitor will be given his transmitter when he occupies the starting area so that he can perform a radio check. If there is a frequency conflict he must be allowed a maximum of one (1) minute for a radio check before the start of the one (1) minute starting time. The timer will notify the competitor when the minute is finished and immediately start timing the one (1) minute starting time.

5.9.12 Execution of Manoeuvres

- a) In the preliminary flights (schedule F3P-AP) and the finals flights (schedule F3P-AF), the manoeuvres must be executed during an uninterrupted flight in the order that they are listed on the score sheet. The direction of take-off is the competitor's choice. The direction of each manoeuvre is determined as a result of the take-off direction.
- b) In schedules with turn around manoeuvres, there is no unjudged flying between the first manoeuvre after the take-off and the last manoeuvre before landing.
- c) In AFM, judging is done for the entire flight, without interruption.
- d) If the model aircraft touches the floor, ceiling, walls, or any structures or fixtures of the hall, or crosses

the safety line during a manoeuvre, this manoeuvre is scored ZERO.

- e) In AFM this rule only applies regarding the safety line.
- f) The competitor may make only one attempt at each manoeuvre during the flight. The pilot has one (1) minute to start his motor and five (5) minutes to complete his flight, both the one (1) minute and the five (5) minutes to start when the competitor is given permission to start.
- g) In AFM the competitor has to signal the operator of the music his wish to start the music within the first (1) minute.
- h) The duration of the music must be 120 +/- 5 seconds. Judging of the flight starts with its beginning.
- i) The model aircraft must take-off and land unassisted, that is, no hand launched flights. If any part of the model aircraft is dropped or if it comes to stand still during the flight, scoring will cease at that point and the model must be landed immediately.
- j) In AFM this rule only applies regarding the take-off.
- k) The flight ends when the landing sequence is completed. Scoring will cease at the expiry of the five (5) minutes time limit.
- l) In AFM the flight ends at the stop of the music, or 125 seconds after it had started. At least then the model aircraft has to be landed.

5.9.13 Schedule of Manoeuvres

The schedule F3P-AP is a preliminary schedule for expert pilots in Indoor Aerobatic Power Model Aircraft competitions.

The schedule F3P-AF is a finals schedule for expert pilots in Indoor Aerobatic Power Model Aircraft competitions.

The schedule F3P-AFM is for competitors to demonstrate their artistic performances in Indoor Aerobatic Power Model Aircraft in conjunction with music. It is recommended that competitors in F3P-AFM have to go through a prequalification in F3P-AP and F3P-AF first.

SCHEDULE F3P-AP

K-Factor

AP 01.	Take-off Sequence	0
AP02.	Loop with full integrated roll (Centre manoeuvre)	5
AP03.	Half square of horizontal knife edge	4
AP04.	45 degree upline with 4-point roll (Centre manoeuvre)	4
AP05.	Inverted half circle (Turn-around manoeuvre)	2
AP06.	Reverse cuban eight from top (Centre manoeuvre)	4
AP07.	Half square loop from top with half-roll down (Turn-around manoeuvre)	4
AP08.	1½ rolling circle with three opposite half-rolls integrated (Centre manoeuvre)	5
AP09.	Stall turn with half roll up (Turn-around manoeuvre)	3
AP10.	Two half torque rolls ((Centre manoeuvre)	6
AP11.	Half-square loop (Turn-around manoeuvre)	2
AP12.	One-turn spin (Centre manoeuvre)	3
AP13.	Landing Sequence	0

SCHEDULE F3P-AF

K-Factor

AF01.	Take-off sequence	0
AF02.	Square loop on corner with two half-rolls (Centre manoeuvre)	5
AF03.	Top hat, horizontal knife-edge with half-roll (Turn-around manoeuvre)	4
AF04.	Horizontal eight with ¼-roll, full roll, and ¾-roll integrated (Centre manoeuvre)	5
AF05.	Half square loop, with half roll (Turn-around manoeuvre)	4
AF06.	One-turn inverted spin (Centre manoeuvre)	3
AF07.	Stick back tailslide, half roll up (Turn-around manoeuvre)	3

cont/...

AF08.	Two vertical rolls opposite (Centre manoeuvre)	6
AF09.	Inverted top hat with ¼-rolls (Turn-around manoeuvre)	4
AF010.	Outside loop with full roll integrated (Centre manoeuvre)	5
AF011.	Half circle (Turn-around manoeuvre)	2
AF012.	45 degree downline with two half rolls (Centre manoeuvre)	4
AF013.	Landing sequence	0

The descriptions of the manoeuvres and the Aresti diagrams for F3P-AP and F3P-AF appear at Annex 5M

An explanation of the Aresti diagrams appears in F3A Annex 5A.

The Judge's Guide appears in F3A Annex 5B.

SCHEDULE F3P-AFM

AM1. Take-off

AM2. Freestyle (freely composed sequence of manoeuvres choreographed to music of the competitor's choice.)

AM3. Landing

The description of the manoeuvres for F3P-AFM appear at the end of Annex M.

5.9.14 Manoeuvres for F3P-AP and F3P-AF R/C Indoor Aerobatic Power Model Aircraft

All manoeuvres are judged on flight path and will start and finish in straight and level upright or inverted flight. Centre manoeuvres will start and finish on the same heading, while turn-around manoeuvres will finish on a heading 180° to entry. When appropriate, entry and exit of centre manoeuvres will be at same altitude. Positioning adjustments in altitude are allowed in turn-around manoeuvres.

All manoeuvres which have more than one loop or part of loops will have the loops or part loops of the same diameter and in case of consecutive loops, in the same place. Similarly all manoeuvres which have more than one continuous roll will have the same roll rate. All manoeuvres which have more than one point roll will have the same roll rate, and points will be of equal duration. All consecutive rolls on a horizontal line will be at the same altitude and heading.

All manoeuvres with rolls, part of rolls or snap rolls, or combination of same, will have lines of equal length before and after the rolls or combinations except in Immelmann or Split S families. Snap rolls that are not snap rolls (ie barrel rolls) will be scored zero. Spins that are spiral dives or have a snap roll entry will be scored zero.

Any violation of above will be reason for downgrading, in addition to the violations referred to in the judging notes listed in the manoeuvre descriptions and downgrades noted in the Judges Guide (F3A Annex 5B) and the official judging training video. Note that these lists are not all-inclusive.

ANNEX 5M

F3P – RADIO CONTROLLED AEROBATIC MODEL AIRCRAFT DESCRIPTION OF MANOEUVRES

Preliminary Manoeuvres – Schedule F3P-AP

AP01. Take-off sequence

Place the model aircraft on the floor and take-off parallel to the security line. After reaching a reasonable height, turn 180° away from the security line.

Judging Notes:

- Take-off sequence is not scored

AP02. Loop with full integrated roll (Centre manoeuvre)

Perform an inside loop with a full roll, completely integrated.

AP03. Half square of horizontal knife edge (Turn-around manoeuvre)

Perform a quarter roll, followed immediately by a horizontal half square in knife-edge flight, followed immediately by a second quarter roll to exit inverted.

Judging notes:

- The two radii of the half square corners must be equal.
- The altitude must not vary during the entire manoeuvre.

AP04. 45 degree upline with 4-point roll (Centre manoeuvre)

From inverted, push to a 45° upline and perform a four-point-roll, to exit inverted.

AP05. Inverted half circle (Turn-around manoeuvre)

Perform half a circle of inverted flight of constant radius and at a constant altitude..

AP06. Reverse cuban eight from top (Centre manoeuvre)

Pull to a 45° downline and perform a half roll. Then pull through a 3/4 inside loop to a 45° downline, perform a half roll, pull through a 5/8 inside loop, to exit inverted.

AP07. Half square loop from top, with half roll down (Turn-around manoeuvre)

Pull to a vertical downline, perform a half roll, and push to exit inverted.

AP08. 1 ½ rolling circle with three opposite half-rolls, integrated (Centre manoeuvre)

From inverted, perform a 540° rolling circle, with three half rolls in opposite directions integrated in each 180° section. First half roll to the outside.

Judging notes:

- The circles must have constant radii, and constant roll rates
- The altitude must not vary during the entire manoeuvre

AP09. Stall turn with half roll up (Turn-around manoeuvre)

Pull to a vertical upline, perform a half roll, followed by a stall turn to a vertical downline. Push to exit inverted.

Judging Notes:

- Radius of turn of more than 1½ wingspan scores zero (0)

cont/...

AP10. Two half torque rolls (Centre manoeuvre)

From inverted, reduce flying speed until the longitudinal axis of the model aircraft is in a vertically hovering attitude. Perform a half torque roll in this position, followed immediately by a half torque roll in the opposite direction, then accelerate the model aircraft to exit inverted.

Judging notes:

- The altitude and distance from the security line must be constant during the entire manoeuvre.

AP11. Half square loop (Turn-around manoeuvre)

Push to a vertical upline, and complete a half square loop.

AP12. One-turn Spin (Centre manoeuvre)

From level flight, reduce flying speed until the model stalls. Perform a one-turn spin, then recover to level flight. Exit level.

AP13. Landing sequence

Reduce power and perform a 180° turn. Land the model aircraft gently, parallel to the security line.

Judging Notes:

- Landing sequence is not scored.

The Aresti diagrams appear overleaf.



F3P INDOOR AEROBATICS PRELIMINARY SCHEDULE AP (from January 2009)

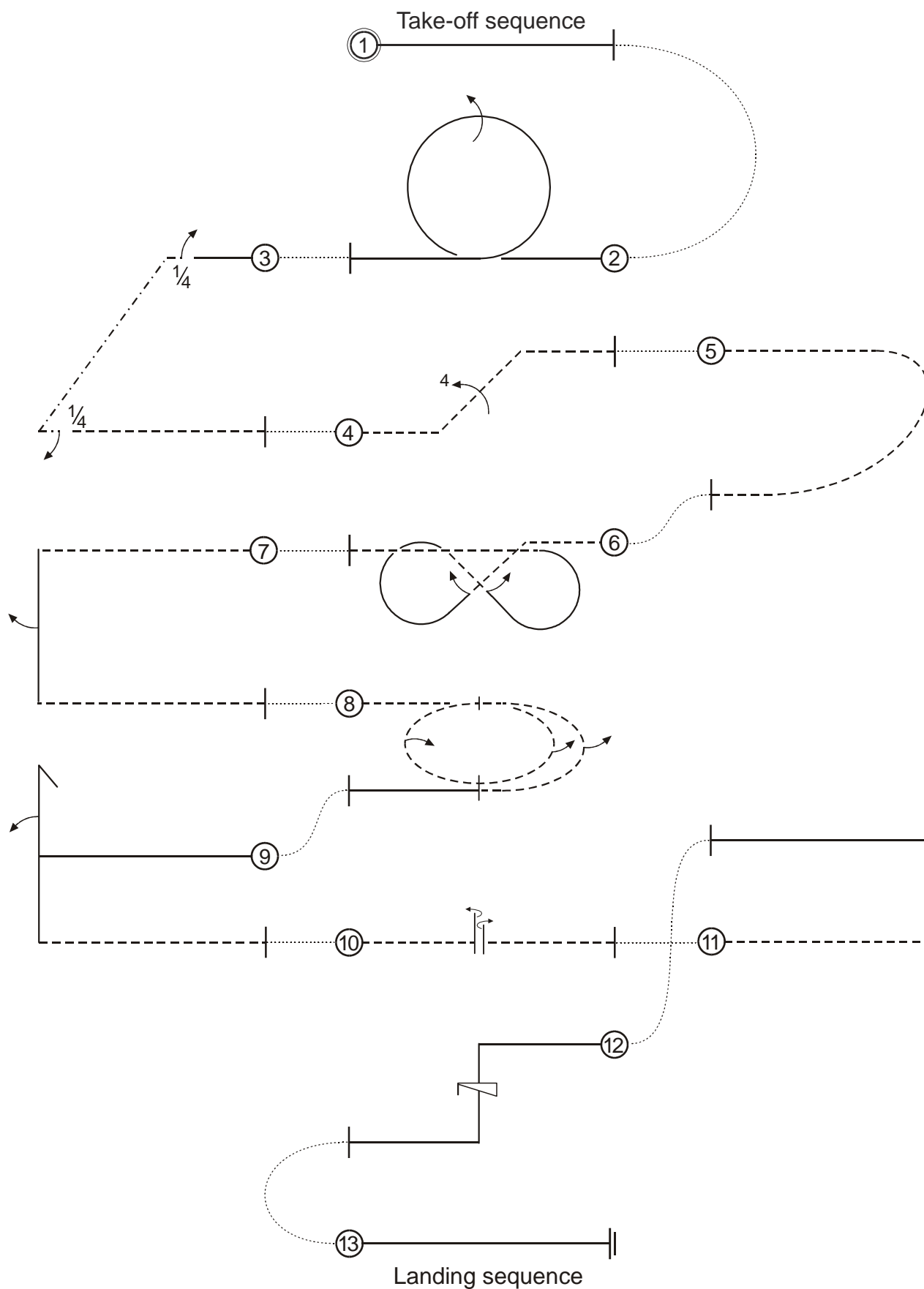

Drawings by Bob Skinner
(CorelDraw 9, January 2009)



Finals Manoeuvres – Schedule F3P-AF



AF01. Take-off sequence

Place the model aircraft on the floor and take-off parallel to the security line. After reaching a reasonable height, turn 180° away from the security line.

Judging notes:

- Take-off sequence is not scored

AF02. Square Loop on corner with two half-rolls (Centre manoeuvre)

Pull to a 45 degree upline and complete a square loop on corner. In the second and third leg, perform a half roll, to recover upright.

AF03. Top Hat, horizontal knife-edge with half-roll (Turn-around manoeuvre)

Pull to a vertical upline, and perform knife-edge horizontal flight, cross-box, with a half-roll. Perform a vertical downline and push to exit inverted.

AF04. Horizontal eight with ¼-roll, full roll, and ¾-roll integrated (Centre manoeuvre)

From inverted perform 90° of a rolling circle with one quarter of a roll to the outside, integrated, followed immediately by a 360° circle in opposite direction with a full roll to the outside, integrated, followed immediately by a 270° circle in opposite direction, with three quarters of a roll to the outside, integrated, to exit inverted.

Judging notes:

- The circles must have constant radii, and be of the same diameter
- The altitude must not vary during the entire manoeuvre
- The roll rates must be constant.

AF05. Half square loop, with half roll (Turn-around manoeuvre)

Push to a vertical upline, perform a half roll, and pull to exit inverted.

AF06. One turn inverted spin (Centre manoeuvre)

From inverted flight, reduce flying speed until the model stalls. Perform a one-turn inverted spin, then recover into inverted flight. Exit inverted.

AF07. Stick back tailslide, half roll up (Turn-around manoeuvre)

Push to a vertical upline, perform half a roll, followed by a stick-back tailslide to a vertical downline. Push to exit inverted.

Judging Notes:

- Stick-forward tailslide scores zero (0).

AF08. Two vertical rolls opposite (Centre manoeuvre)

From level inverted flight, push to a vertical upline. Perform a full roll, followed immediately by a full roll in opposite direction. Push to exit upright.

AF09. Inverted top hat with ¼ rolls (Turn-around manoeuvre)

Push to a vertical downline, perform a quarter roll, push to horizontal inverted cross-box flight. Push to a vertical upline, perform a quarter roll, and push to exit upright.

AF10. Outside loop with full roll integrated (Centre manoeuvre)

Push and perform an outside loop, with a full roll completely integrated. Exit upright.

AF11. Half circle (Turn-around manoeuvre)

Perform a half circle of constant altitude and constant radius.

AF12. 45 degree downline with two half rolls (Centre manoeuvre)

Push to a 45° downline, and perform two half rolls spaced equally over the centre line. Exit upright.

AF13. Landing sequence

Reduce power and perform a 180° turn. Land the model aircraft gently, parallel to the security line.

Judging notes:

- Landing sequence is not scored.

The Aresti diagrams appear overleaf.



F3P INDOOR AEROBATICS FINALS SCHEDULE AF (from January 2009)

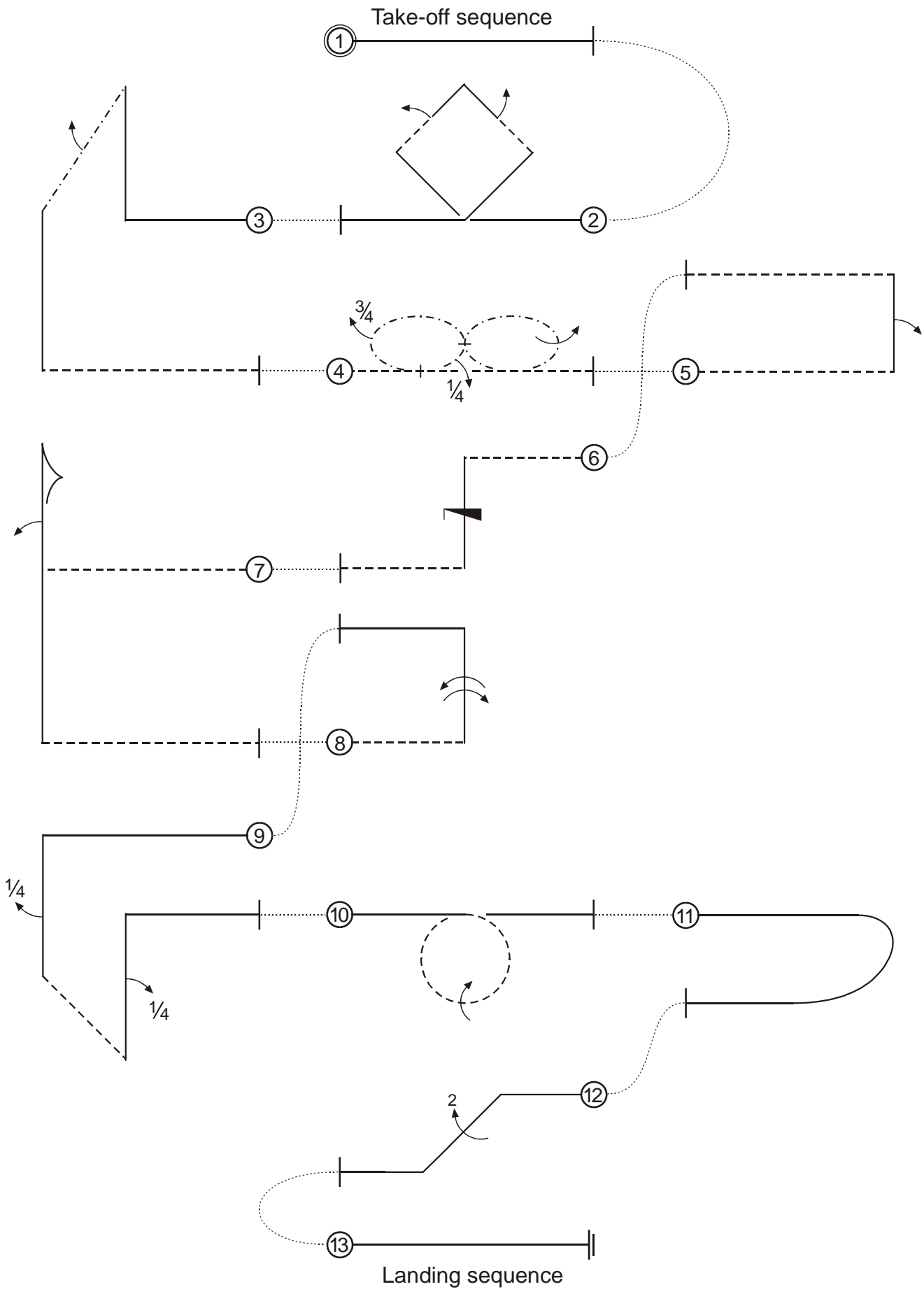

Drawings by Bob Skinner
(CorelDraw 9, January 2009)

Manoeuvres – Schedule F3P-AFM

AFM1. Take-off Sequence

Place the model aircraft on the floor and take-off.

AFM2. Freestyle

A sequence of manoeuvres, freely composed by the competitor and flown in harmony to simultaneously played music of his choice. Any possible flight manoeuvres may be flown and "show effects" presented, as long as safety is not compromised and conformity to the rules is met. It is permitted to perform different programs in conjunction with different music in each round. The performance is judged for the entire flight from start to finish and in accordance to the following three criteria:

	K Factors
1 Flying Style	
- Precision of manoeuvres	2
- Utilisation of flight performance scope/difficulty of manoeuvres	2
-Variety of manoeuvres/new manoeuvres	2
2 Artistic Quality	
- Synchronisation to music.....	3
- Reflection of the mood of the music/show effects	2
- Sequence of quiet and dynamic phases.....	1
3 Overall Impression	
- Utilisation of manoeuvring area	2
- Continuity of schedule	2
- Positioning/safety.....	2

Judges Notes:

Unlike class F3A, although accompanied by its basic rules, F3P-AFM mostly focuses on spectator and media efficacy. This is why the performances should be extraordinarily spectacular and entertaining under these aspects.

For the Judges it is recommended to make "pencil" notes right away during the presentation. So corrections are still possible in course of the flight. All three criteria have to be marked simultaneously and evenly.

Although it is subjective, judging the presentations has to follow the judging guide and judging notes. Bias in favour of, or against, particular persons, models, music pieces etc must not influence the judging.

1 Flying Style

The flying skills of the pilot count herein. Flight sections and manoeuvres should be precise in the sense of F3A. Difficult manoeuvres are marked higher. The pilot is to demonstrate that he safely governs his model in any position. (Judges Guide F3A Annex 5B)

In addition, the pilot is to utilise the full flight performance scope of his model. Fast and slow flying, snap manoeuvres, hovering etc. The manoeuvres should show positive as well as negative "g"-portions: loops, rolls, snaps, spins, stall-turns, tailslides, hovering, torque-rolls, flat circles, Lomcevacs, circles, etc. New or extraordinary manoeuvres are marked higher. Frequent repetition of the same manoeuvre has to be downgraded respectively. Manoeuvres should be positioned in parallel or rectangular to the security line. Poorly governed, unplanned or casually flown manoeuvres will be downgraded. The same applies to phases less extraordinarily attractive.

cont/...

2 Artistic Quality

The music (choreography) has to enhance the presentation and to create a complimentary atmosphere. The flight performance should be synchronised with the music and must not be a "3D-sketch" with background music. On the other hand the music must not detract from the presentation. The selected music piece(s) should contain fast-slow, soft-loud and dramatic sections. The manoeuvres should follow the music and end with it. The mood of the selected music should be reflected in the manoeuvres and the presentation. Show effects can support this. Music pieces with little contrast, variety or tempi result in downgrades.

3 Overall impression

A well made combination of flying style-music-entertainment is desired. The presentation should fill the manoeuvring area and form an uninterrupted unit with fluent transitions between the individual elements. Various thrill effects are requested. The performance should be orientated towards judges and spectators, although risky flying towards judges and spectators will result in downgrades.

AFM3. Landing Sequence

The termination of the flight in any kind of way provided it is performed in a safe manner.



ANNEX 5N
RULES FOR WORLD CUP EVENTS
F3A AEROBATIC WORLD CUP

5N.1. Class

The F3A class is recognised for World Cup competition (aerobatic model aircraft).

5N.2. Competitors

All competitors in the specified open international contests are eligible for the World Cup.

5N.3. Contests

Contests included in the World Cup must appear on the FAI Contest Calendar, and must be run according to the FAI Sporting Code. The contests eligible for a World Cup in a particular year, must be nominated before the CIAM Bureau Meeting at the end of the preceding year, and must be included in the FAI Contest Calendar. The selection of the contests should be according to the following guidelines:

- a) a maximum of two contests may be selected for any one country.
- b) each competitor may count only one competition from each country in Europe (taking the better score for any European country in which he has scored in two competitions).

5N.4. Points allocation

The points to be allocated to competitors will depend on the number (N) of competitors who have completed at least one flight in the event. A competitor has completed a flight if he registers a score greater than zero (0).

Points are allocated to competitors who have completed at least one flight in the event, according to their placing in the results, as given in the following tables:

a) **N>20**

Placing	1	2	3	4	5	6	20	21 and after
Points	20	19	18	17	16	15	1	0

A bonus of 8 points is given to the first placed competitor; 5 points to the second placed and 3 points to the third placed.

b) **N=<20**

Placing	1	2	3	4	5	6	N-1	N
Points	N	N-1	N-2	N-3	N-4	N-5	2	1

The bonus is defined as follows:

- for first place: $N/3$ rounded up to the nearest whole number of points, with a maximum of 7 points;
- for second place: $N/5$ rounded up to the nearest whole number of points, with a maximum of 4 points;
- for third place: $N/7$ rounded up to the nearest whole number of points, with a maximum of 3 points.

In the event of a tie between competitors for any placing, the competitors will share the points which would have been awarded to the places covered had the tie been resolved (round up the score to the nearest whole number of points).

5N.5. Classification

The World Cup results are determined by considering the total of points obtained by each competitor in the World Cup events. Up to three events may be counted, selecting each competitor's best scores during the year. The winner of the World Cup is the competitor with the greatest total.

In the event of a tie for first, second, and third place, the place will be determined according to the following criteria:

The number of events counted is increased, one at a time, from three until the winner is obtained. If this does not separate the tied competitors, then the winner will be determined by considering the points obtained in the best three events multiplied by the number of competitors who have completed at least one flight in the event. The winner is the one with the greatest total thus calculated.

5N.6. Awards

The winner is awarded the title of winner of the World Cup. Certificates, medals and trophies may be awarded by the CIAM F3A sub-committee if available.

5N.7. Organisation

The F3A sub-committee shall be responsible for organising the World Cup, and may nominate a responsible person or special sub-committee to collate the results.

5N.8. Communication

The F3A sub-committee (nominated World Cup coordinator) must receive the results from each contest in the World Cup, and then calculate and publish the World Cup positions. These should be distributed to the news agencies and should also be available, by payment of a nominal fee, to any interested bodies or individuals. Final results of the World Cup must be sent to the FAI, National Airports Controls, and the modelling press.

5N.9. Responsibilities of competition organisers

Competition organisers must propose their event for inclusion in the World Cup, when nominating events for the FAI international Sporting Calendar. The final selection of events from these proposals is made by the CIAM Bureau as defined in paragraph 3.

Immediately after the event, the competition organiser must send the results to the World Cup coordinator, within one month as required in the Sporting code B.2.5. Any failure to return scores promptly will be reviewed by the CIAM Bureau when considering the competition calendar for the following year.

5N.10. Board of judges

A board of three responsible people shall be nominated by the CIAM F3A sub-committee to rule on any protest concerning the World Cup during a year. Any protest must be submitted in writing to the F3A sub-committee chairman and must be accompanied by a fee of 35 Euros. In the event of the jury upholding the protest, the fee will be returned.